

# MQ 3-45

WATTS INSTRUCTIONS



 [Watts.com/MQPump](https://www.watts.com/MQPump)

[Watts.com](https://www.watts.com)

 **WATTS®**

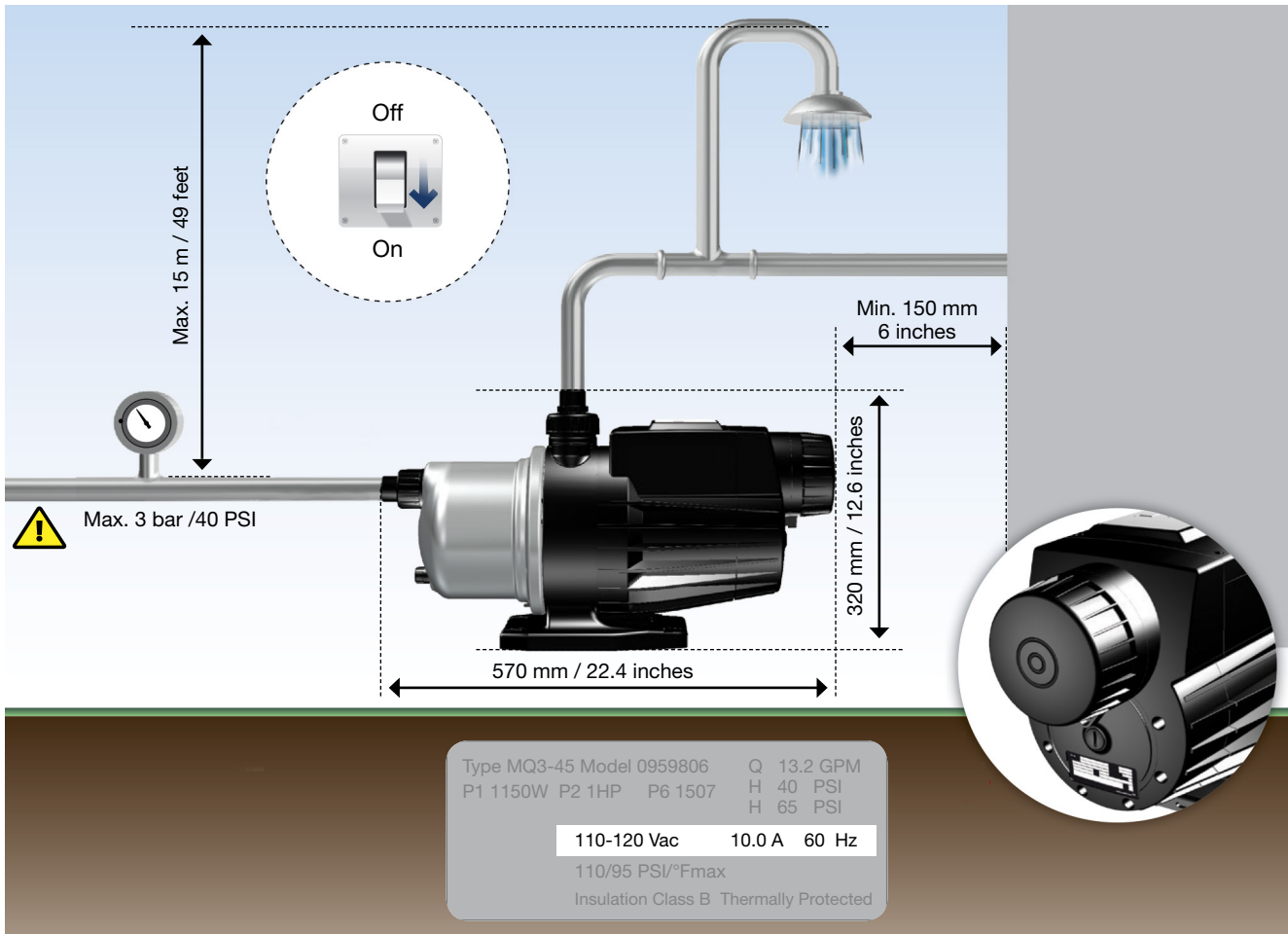

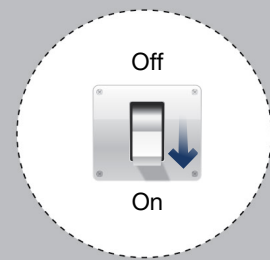
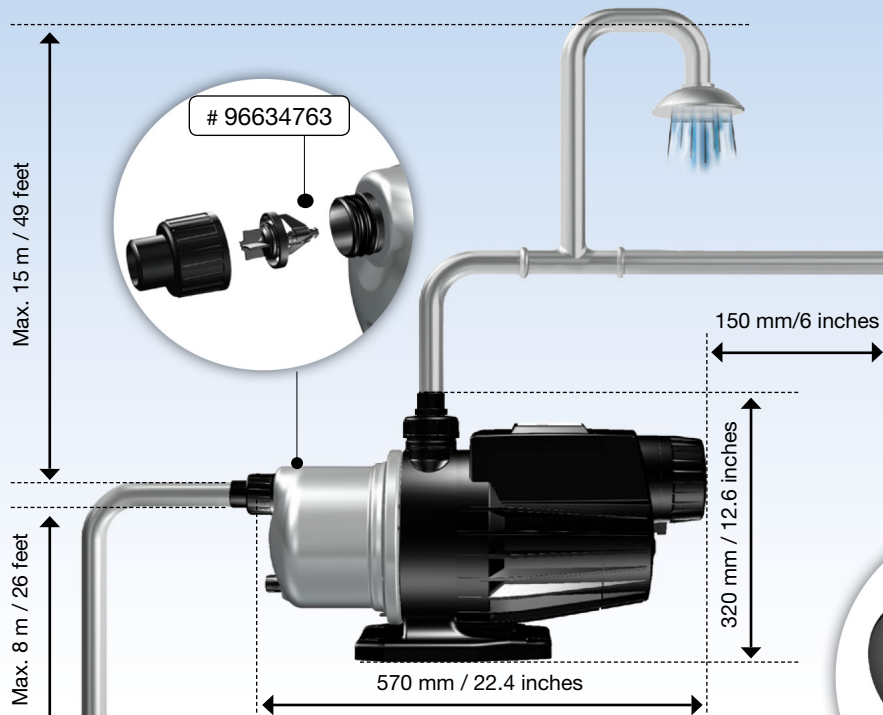

Type MQ3-45 Model 0959806 Q 13.2 GPM  
 P1 1150W P2 1HP P6 1507 H 40 PSI  
 H 65 PSI

110-120 Vac 10.0 A 60 Hz

110/95 PSI/°Fmax

Insulation Class B Thermally Protected

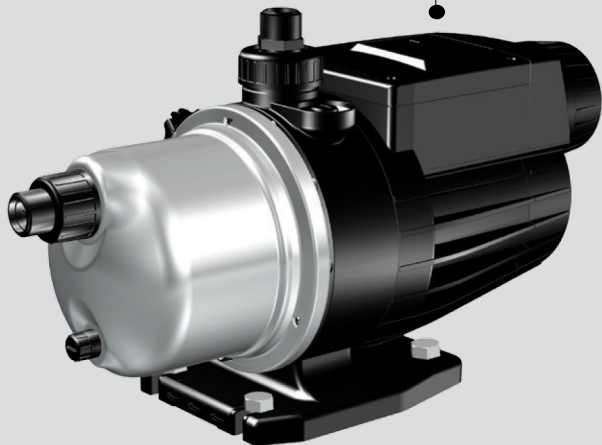
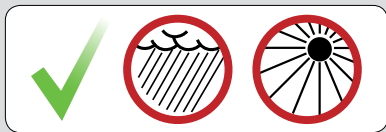

1

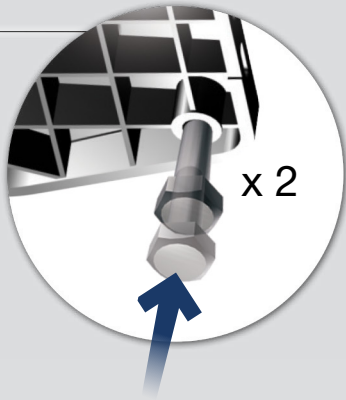
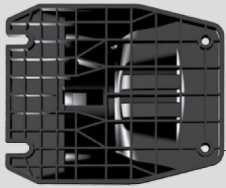
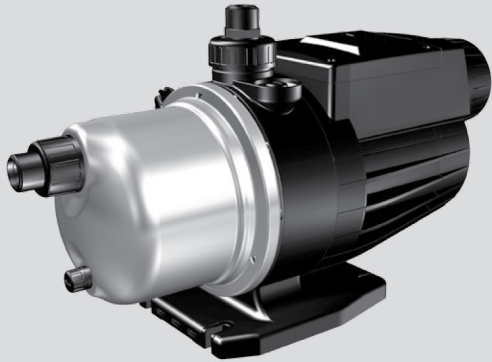

190 mm / 7.5 inches

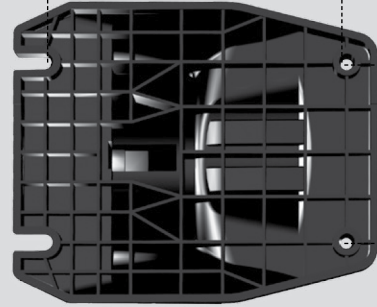

114 mm /  
4.5 inches

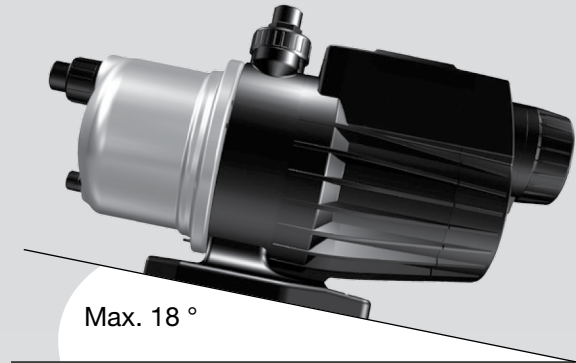

Max. 18°



2

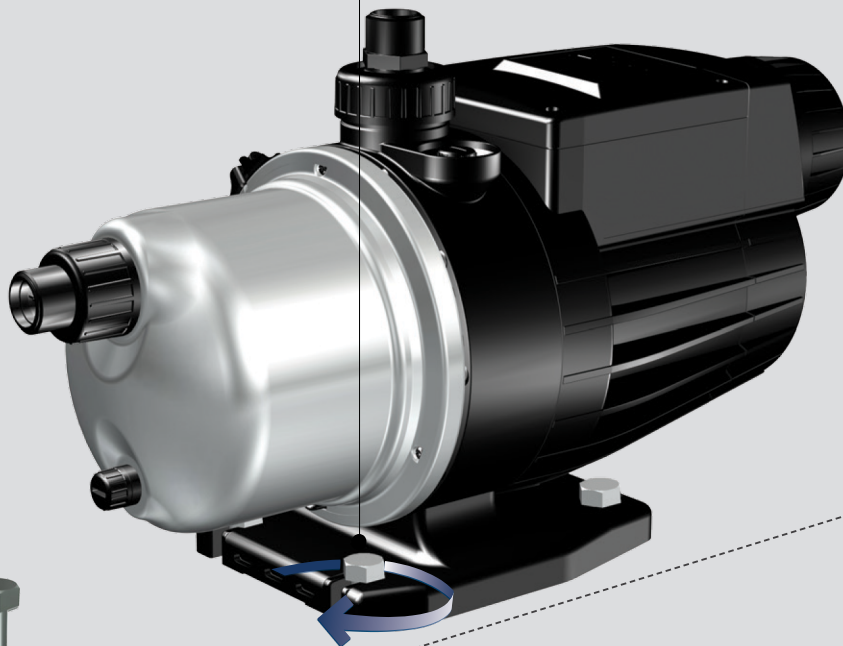
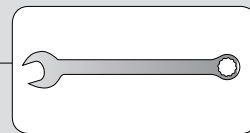

4 x

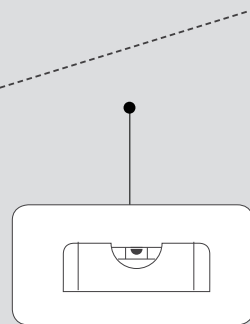

3

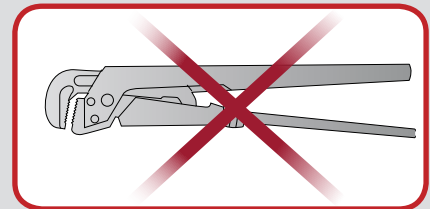
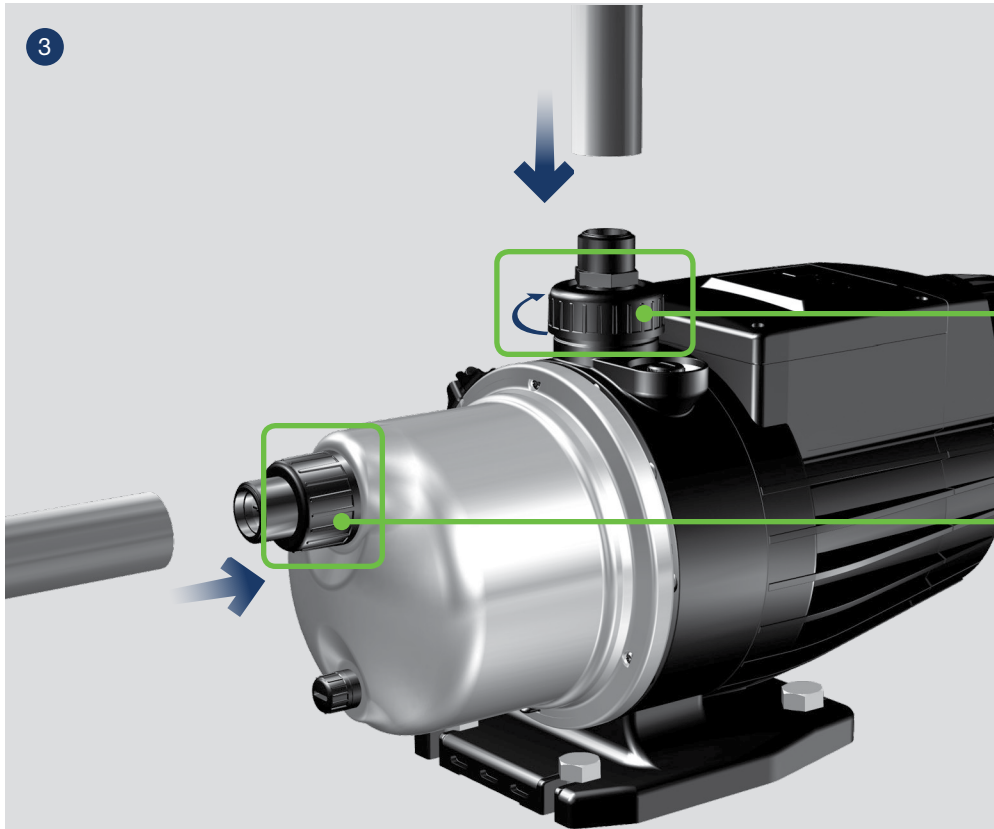

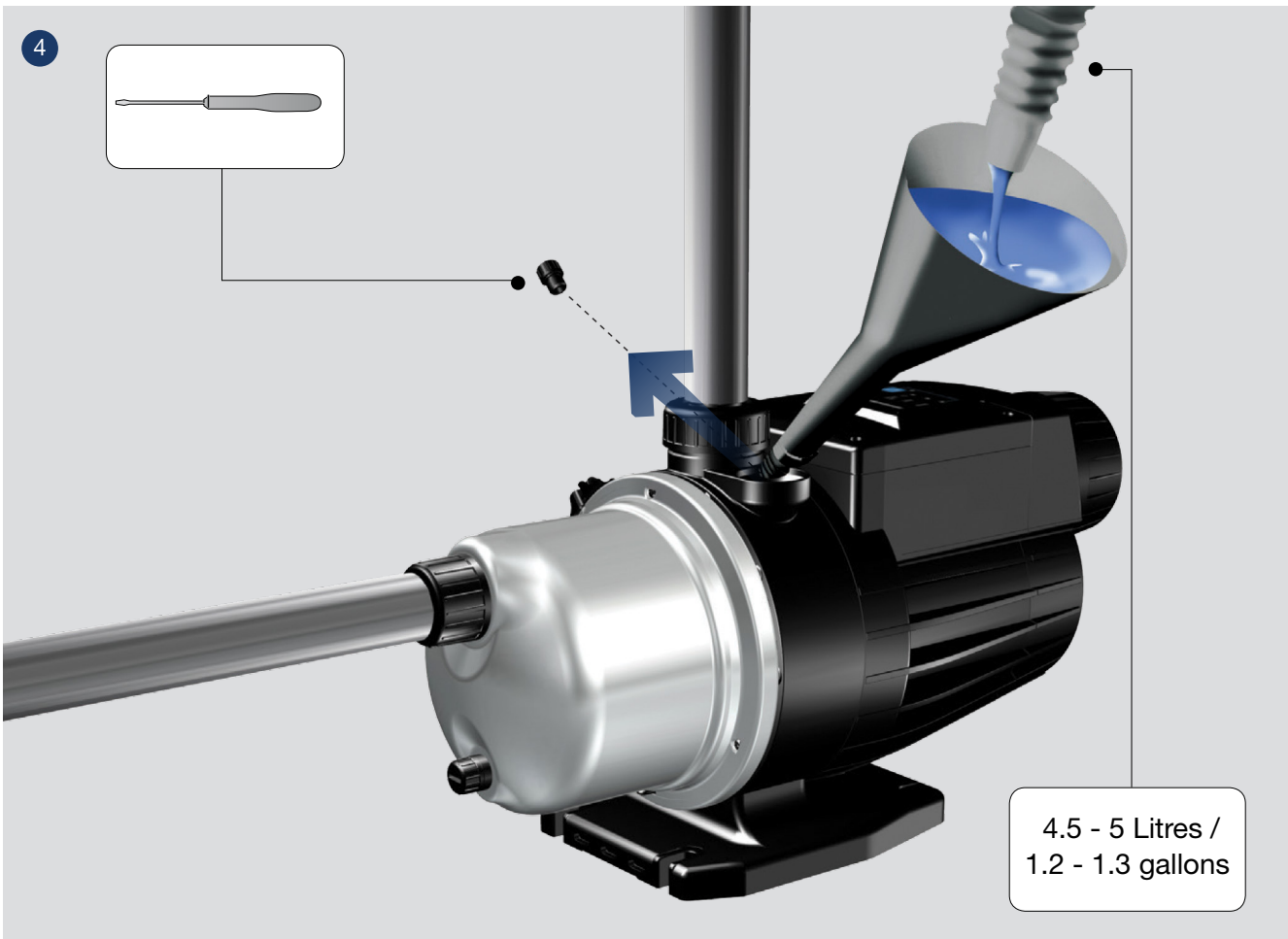



5

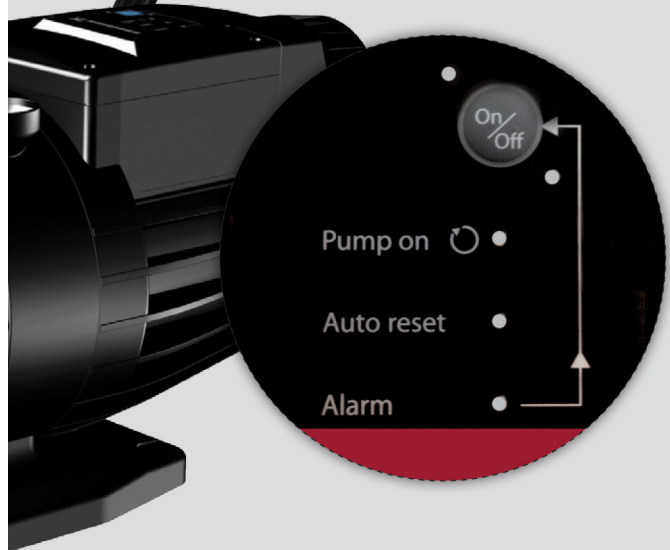

6

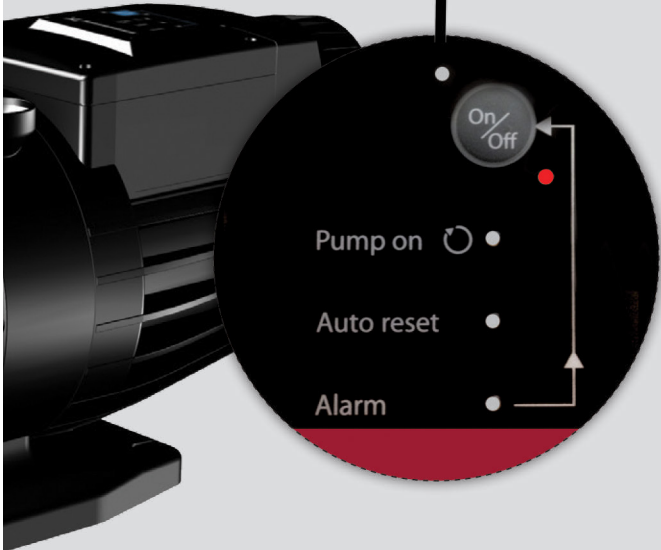

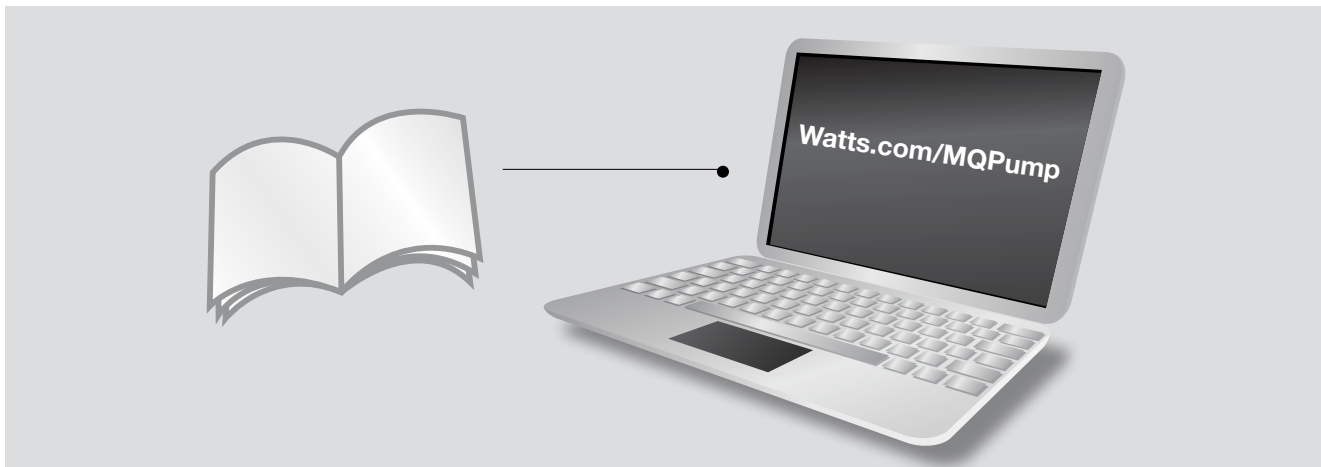
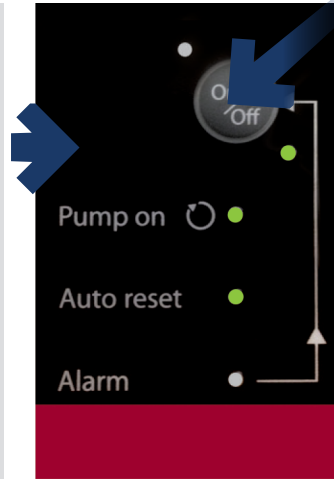
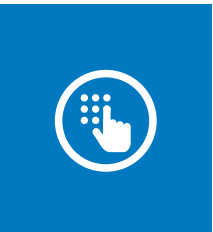
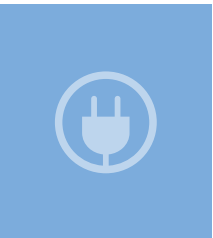



96450698



96526663



98652420



96634763



96693071

