

For Residential and Commercial Applications

Job Name _____

Contractor _____

Job Location _____

Approval _____

Engineer _____

Contractor's P.O. No. _____

Approval _____

Representative _____

Series X65B

Water Pressure Reducing Valves* Rough-In Kit and Cartridge Assembly

Sizes: 1/2" – 2" (15 – 50mm)

Series X65B Water Pressure Reducing Valves are cartridge style regulators and are orderable three ways: Complete, ready-to-install Regulators, or separate Rough-in Kits consisting of a bronze body with integral strainer, or separate Cartridge Assemblies.

The Rough-in Kit is installed permanently into the water line eliminating the need for jumper kits. The unique strainer/cap assembly is used during the construction phase. Later at system start-up, remove the strainer/cap assembly and insert the Cartridge Assembly. The Strainer is easy to clean once you remove the cap with a wrench.

The Cartridge Assembly is simply installed by removing the strainer/cap assembly and inserting the Cartridge Assembly into the valve body and turning clockwise—no tools needed for installation.

The innovative spring Cartridge Assembly design allows for easy replacement in-line if service is needed. Cartridge Assemblies are available in a standard pressure range of 20 - 80psi (138 - 552 kPa), preset at the factory to 50psi (345 kPa) or in a high-pressure (HP) range of 50 - 150psi (345 kPa - 10.3 bar), preset at the factory to 100 psi (6.9 bar).

Features

- Rough-in Kit consists of valve body and strainer/cap assembly and eliminates expensive jumper kits while protecting the downstream plumbing system.
- Rough-in Kit has uniquely designed integral basket strainer for easy removal and replacement
- Rough-in Kit consists of a bronze body construction
- Union tailpiece kits available for Quick-Connect, PEX, and CPVC, solder, and thread connections.
- Cartridge Assembly serviceable in-line and easy to install without tools
- Cartridge Assembly with engineered seat design reduces possible flow noise
- 100% balanced valve, unique to Watts, provides reliable flow performance.
- Cartridge Assembly is available in standard pressure 20 - 80psi (138 - 552kPa) and HP models 50 -150psi (345 kPa – 10.3 bar)
- Cartridge Assembly bypass feature** controls thermal expansion pressure



X65B Rough-in Kit

X65B Cartridge Assembly

Specifications

A water pressure reducing valve Rough-in Kit with strainer/cap assembly shall be installed during construction in the water service pipe near its entrance to the building where supply main pressure exceeds 60psi (413 kPa) to reduce it to 50psi (345 kPa) or lower. The Rough-in Kit shall feature a bronze body suitable for water supply pressure up to 400psi (26.7 bar) and strainer/cap assembly.

Once the Cartridge Assembly is installed, provision shall be made to permit the bypass flow of water back through the valve into the main when pressures, due to thermal expansion on the outlet side of the valve, exceed the pressure in the main supply. Approved valve shall be listed to ASSE 1003 and IAPMO and certified to CSA B356. Valve shall be a Watts Series X65B.

* A water saving test program concluded that reducing the supply pressure from 80 to 50psi (551 – 345kPa) resulted in a water savings of 30%.

** The bypass feature will not prevent the pressure relief valve from opening on the hot water supply system with pressures above 150psi (10.3 bar).

Watts product specifications in U.S. customary units and metric are approximate and are provided for reference only. For precise measurements, please contact Watts Technical Service. Watts reserves the right to change or modify product design, construction, specifications, or materials without prior notice and without incurring any obligation to make such changes and modifications on Watts products previously or subsequently sold.



Models

X65B Rough-in Kit – NPT threaded female inlet x NPT female outlet

X65BU Rough-in Kit – NPT threaded female union inlet x NPT female outlet

X65BDU Rough-in Kit – Double Union – NPT threaded union female inlet and outlet

X65BUS Rough-in Kit – Solder union inlet x NPT female outlet

X65BDUS Rough-in Kit Double Union – Solder union inlet and outlet

X65BU-QC Rough-in Kit Single Union – Quick-Connect union inlet x NPT female outlet*

X65BDU-QC Rough-in Kit Double Union – Quick-Connect union inlet and union outlet*

X65BDU-CPVC Rough-in Kit – Double Union CPVC Union Inlet x CPVC Union Outlet**

X65BDU-PEX Rough-in Kit – Double Union PEX Union Inlet x PEX Union Outlet*

X65 Cartridge Assembly – standard pressure range 20 - 80psi

X65 Cartridge Assembly – high pressure range 50 – 150psi

*For sizes 1/2", 3/4", 1" (15, 20, 25mm) Only

**For sizes 3/4", 1" (20, 25mm) Only

Dimensions – Weights

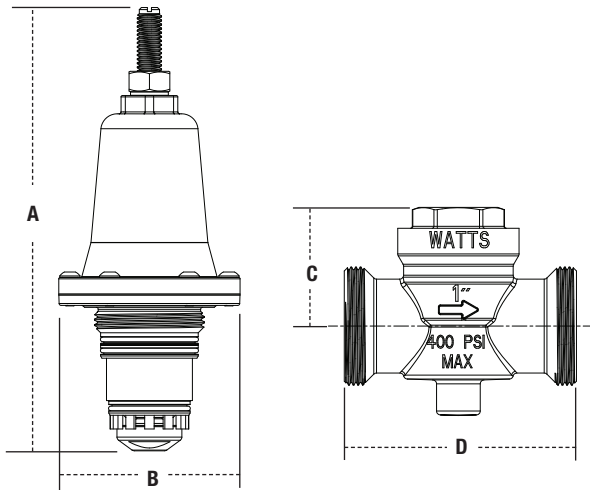

Size		DIMENSIONS								WEIGHT	
in.	mm	A		B		C		D		lbs.	kgs.
		in.	mm	in.	mm	in.	mm	in.	mm		
1/2	15	5 7/16	138	2 7/16	61	1 11/16	42	3	77	0.7	0.3
3/4	20	5 7/16	138	2 7/16	61	1 11/16	42	3 1/8	80	0.8	0.4
1	25	6 13/16	173	2 3/4	71	1 13/16	46	3 9/16	90	1.1	0.5
1 1/4	32	7	178	3 1/4	82	2 3/8	60	4 5/16	110	1.8	0.8
1 1/2	40	11 1/2	292	4 9/16	116	2 7/8	72	5 1/2	140	3.6	1.6
2	50	11 1/2	292	4 9/16	116	2 7/8	72	5 1/2	140	4.0	1.8

Materials

Body: Bronze

Cap: Thermoplastic

Strainer: Stainless steel and thermoplastic

Pressure – Temperature

Temperature Range: 33°F – 180°F (0.5°C – 82°C)

Maximum Working Pressure: 400psi (27.6 bar)

Adjustable Reduced Pressure Range: 20 – 80psi (138 – 552 kPa)

Standard Reduced Pressure Setting: 50psi (345 kPa)

HP Reduced Pressure Range: 50-150psi (345 – 1034 kPa)

HP Reduced Pressure Setting: 100psi (6.9 bar)

Standards



As an assembled unit, Rough-in Kit and Cartridge Assembly, meet the requirements of ASSE 1003: and listed by IAPMO.



A Watts Water Technologies Company



ISO 9001-2008
CERTIFIED

USA: Tel. (978) 688-1811 • Fax: (978) 794-1848 • www.watts.com
Canada: Tel. (905) 332-4090 • Fax: (905) 332-7068 • www.wattscanada.com