



RD-500

Super Flow Roof Drain

Tag: \_\_\_\_\_

**SPECIFICATION:** Watts Drainage RD-500 epoxy coated cast iron roof drain with flashing clamp with integral gravel stop, self-locking ductile iron dome, and no hub outlet.

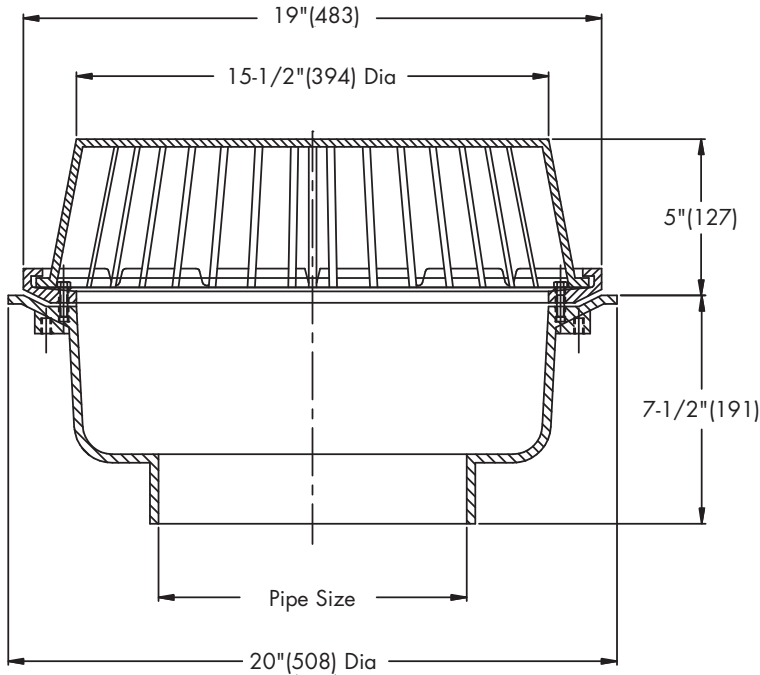

Pipe Size (Select One)	
Suffix	Description
10	10"(254) Pipe Size <input type="checkbox"/>
12	12"(305) Pipe Size <input type="checkbox"/>

Options (Select One or More)	
Suffix	Description
-D	Underdeck Clamp <input type="checkbox"/>
-F	Deck Flange/Adj. Extension <input type="checkbox"/>
-L	Vandal Proof Dome <input type="checkbox"/>
-R	2" External Water Dam <input type="checkbox"/>
-W	2" Internal Water Dam <input type="checkbox"/>

**NOTICE**

The information contained herein is not intended to replace the full product installation and safety information available or the experience of a trained product installer. You are required to thoroughly read all installation instructions and product safety information before beginning the installation of this product

<b>Free Area Sq. In.</b>
<b>275</b>

**Deck Opening 18-1/2"(470)  
with Deck Flange 22-3/8"(568)**

Job Name \_\_\_\_\_

Contractor \_\_\_\_\_

Job Location \_\_\_\_\_

Contractor's P.O. No. \_\_\_\_\_

Engineer \_\_\_\_\_

Representative \_\_\_\_\_

Watts product specifications in U.S. customary units and metric are approximate and are provided for reference only. For precise measurements, please contact Watts Technical Service. Watts reserves the right to change or modify product design, construction, specifications, or materials without prior notice and without incurring any obligation to make such changes and modifications on Watts products previously or subsequently sold.



A Watts Water Technologies Company

**USA:** Tel: (800) 338-2581 • Fax: (828) 248-3929 • Watts.com  
**Canada:** Tel: (905) 332-4090 • Fax: (905) 332-7068 • Watts.ca  
**Latin America:** Tel: (52) 81-1001-8600 • Fax: (52) 81-8000-7091 • Watts.com