

# For Commercial Applications

Job Name \_\_\_\_\_ Contractor \_\_\_\_\_

Job Location \_\_\_\_\_ Approval \_\_\_\_\_

Engineer \_\_\_\_\_ Contractor's P.O. No. \_\_\_\_\_

Approval \_\_\_\_\_ Representative \_\_\_\_\_

Tag \_\_\_\_\_

## RD-300-CP15 Roof Drain With 15" x 15" Promenade Top

### Specification

Watts RD-300-CP15 epoxy coated cast iron roof drain with flashing clamp with integral gravel stop, 15 5/8"x15 5/8"(397x397) square epoxy coated ductile iron heel proof promenade top, and no hub (standard) outlet.

Pipe Sizing (Select One)		
Size	Description	
2	2"(51) Pipe Size	<input type="checkbox"/>
3	3"(76) Pipe Size	<input type="checkbox"/>
4	4"(102) Pipe Size	<input type="checkbox"/>
5	5"(127) Pipe Size (NH Only)	<input type="checkbox"/>
6	6"(152) Pipe Size	<input type="checkbox"/>
8	8"(203) Pipe Size	<input type="checkbox"/>
10	10"(254) Pipe Size (NH Only)	<input type="checkbox"/>

Outlet Type (Select One)		
Size	Description	
NH	No Hub (MJ)	<input type="checkbox"/>
P	Push-On	<input type="checkbox"/>
X	Inside Caulk	<input type="checkbox"/>

Options (Select One or More)		
Size	Description	
-1	All Nickel Bronze Top	<input type="checkbox"/>
-5	Sediment Bucket	<input type="checkbox"/>
-6	Vandal Proof Top	<input type="checkbox"/>
-9	Hinged Grate	<input type="checkbox"/>
-13	Galvanized	<input type="checkbox"/>
-85	4"(102) SS Perforated	<input type="checkbox"/>
	Extension	<input type="checkbox"/>
-B	Sump Receiver	<input type="checkbox"/>
-D	Underdeck Clamp	<input type="checkbox"/>
-E	1" Stackable Clamp	<input type="checkbox"/>
-F	Deck Flange/Adj. Extensions	<input type="checkbox"/>
-US	Buy American Compliant	<input type="checkbox"/>

Load Rating	Free Area Sq. In.
*XHD	57

**Deck Opening 14 1/2"(368)  
With Sump Receiver 18"(457)**

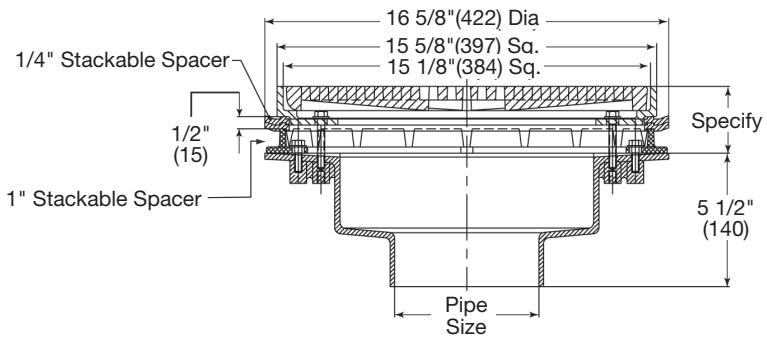
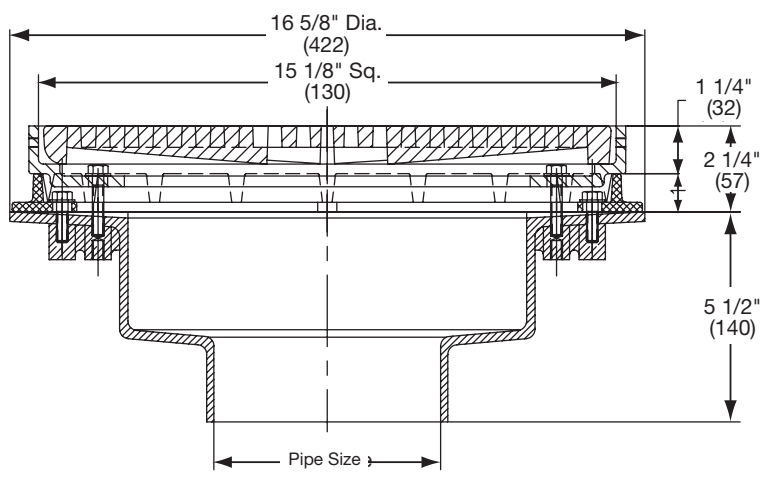

### NOTICE

The load classifications are in accordance with the American National Standards ASME A112.21.1M ASME Ratings are as follows:  
 XHD - Safe Live Load 7500-10,000 lbs. (3375-4500 kg.)  
 The above categories are given as a guide only.  
 Please consult factory.

### NOTICE

The information contained herein is not intended to replace the full product installation and safety information available or the experience of a trained product installer. You are required to thoroughly read all installation instructions and product safety information before beginning the installation of this product.

Watts product specifications in U.S. customary units and metric are approximate and are provided for reference only. For precise measurements, please contact Watts Technical Service. Watts reserves the right to change or modify product design, construction, specifications, or materials without prior notice and without incurring any obligation to make such changes and modifications on Watts products previously or subsequently sold.



USA: T: (800) 338-2581 • F: (828) 248-3929 • Watts.com  
 Canada: T: (905) 332-4090 • F: (905) 332-7068 • Watts.ca  
 Latin America: T: (52) 81-1001-8600 • Watts.com