



RD-100-W

Tag: _____

Large Area Roof Drain with Internal Standpipe

Components:

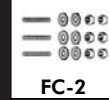

SPECIFICATION: Watts Drainage Products RD-100-W baked epoxy cast iron roof drain with deep sump, wide serrated flashing flange, flashing clamp device with integral gravel stop and self-locking polyethylene dome strainer.

Order Code: RD-100--W--

Ex. RD-102P-W-K

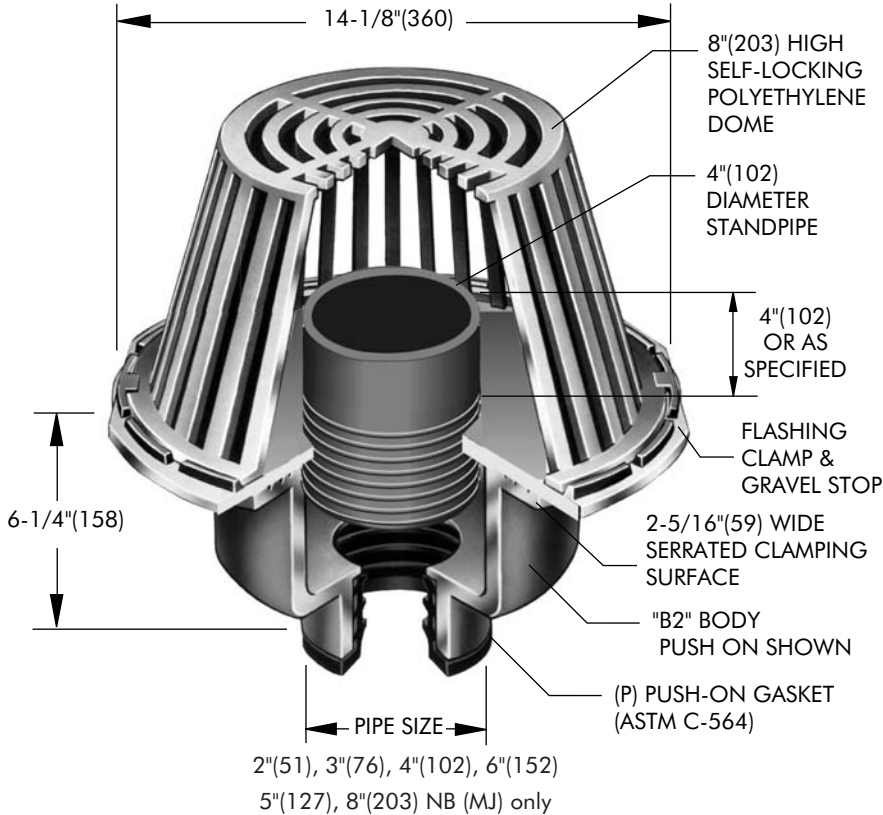

Free Area Sq. In.
137

Deck opening 10" (254)
with sump receiver 13-1/4" (337)

Pipe Sizing (Select One)

Suffix	Description	
2	2"(51) Pipe Size	<input type="checkbox"/>
3	3"(76) Pipe Size	<input type="checkbox"/>
4	4"(102) Pipe Size	<input type="checkbox"/>
5	5"(127) Pipe Size	<input type="checkbox"/>
6	6"(152) Pipe Size	<input type="checkbox"/>
8	8"(203) Pipe Size	<input type="checkbox"/>

Outlet Type (Select One)

Suffix	Description	
NH	No Hub (MJ)	<input type="checkbox"/>
P	Push On	<input type="checkbox"/>
T	Threaded Outlet	<input type="checkbox"/>
X	Inside Caulk	<input type="checkbox"/>

Options (Select One or More)

Suffix	Description	
-A	Accutrol weir (specify # 1-6 slots)	<input type="checkbox"/>
-B	Sump Receiver Flange	<input type="checkbox"/>
-BED	Sump Receiver, Adj Ext., Deck Clamp	<input type="checkbox"/>
-C	Secondary Membrane Clamp	<input type="checkbox"/>
-D	Underdeck Clamp	<input type="checkbox"/>
-E	Adjustable Extension	<input type="checkbox"/>
-GSS	Stainless Steel Ballast Guard	<input type="checkbox"/>
-H	Adj. to 6" IRMA Ballast Guard	<input type="checkbox"/>
-K	Ductile Iron Dome	<input type="checkbox"/>
-K80	Aluminum Dome	<input type="checkbox"/>
-L	Vandal Proof Dome	<input type="checkbox"/>
-R	2" High External Water Dam	<input type="checkbox"/>
-SO	Side Outlet**	<input type="checkbox"/>
-V	Fixed Extension (1-1/2", 2", 3", 4")	<input type="checkbox"/>
-W-1	Waterproofing Flange	<input type="checkbox"/>
-W6	6" Dia. Standpipe, 4" high	<input type="checkbox"/>
-Z	Extended Integral Wide Flange	<input type="checkbox"/>
-12	Galvanized Dome	<input type="checkbox"/>
-13	All Galvanized	<input type="checkbox"/>
-83	Mesh Covered Dome	<input type="checkbox"/>
-113M	Special Epoxy from 3M Range	<input type="checkbox"/>

Optional Body Material (NH Only)

Suffix	Description	
-60	PVC Body w/Socket Outlet	<input type="checkbox"/>
-61	ABS Body w/Socket Outlet	<input type="checkbox"/>

** Side Outlet (-SO) option only available in 2"(51), 3"(76), 4"(102) pipe sizes.
Underdeck Clamp (-BED and -D options) are not available when -SO is selected.

Job Name _____ Contractor _____

Job Location _____ Contractor's P.O. No. _____

Engineer _____ Representative _____

WATTS Drainage reserves the right to modify or change product design or construction without prior notice and without incurring any obligation to make similar changes and modifications to products previously or subsequently sold. See your WATTS Drainage representative for any clarification. Dimensions are subject to manufacturing tolerances.



CANADA: 5435 North Service Road, Burlington, ON, L7L 5H7 TEL: 905-332-6718 TOLL-FREE: 1-888-208-8927 Website: www.wattsdrainage.ca

