

# For Commercial Applications

Job Name \_\_\_\_\_

Contractor \_\_\_\_\_

Job Location \_\_\_\_\_

Approval \_\_\_\_\_

Engineer \_\_\_\_\_

Contractor's P.O. No. \_\_\_\_\_

Approval \_\_\_\_\_

Representative \_\_\_\_\_

Tag \_\_\_\_\_

## OI-ST Oil Interceptor with Integral Storage Tank

### Specification

Watts OI-ST Series recessed or floor mounted epoxy coated steel oil interceptor with integral storage tank, gasketed epoxy coated steel skid-proof cover secured with hex head center bolt(s), deep seal trap with cleanout, draw-off connection and dual vent connections, sediment bucket, integral stainless steel flow control plate, and no hub (standard) connections.

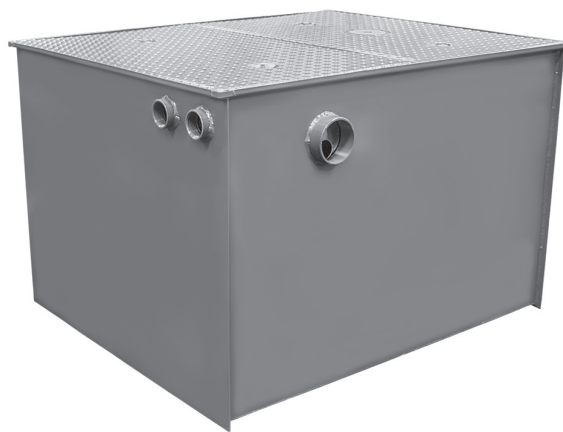

Flow Rate (Select One)		
Size	Description	
10	10 GPM	<input type="checkbox"/>
15	15 GPM	<input type="checkbox"/>
20	20 GPM	<input type="checkbox"/>
25	25 GPM	<input type="checkbox"/>
35	35 GPM	<input type="checkbox"/>
50	50 GPM	<input type="checkbox"/>
75	75 GPM	<input type="checkbox"/>
100	100 GPM	<input type="checkbox"/>
125	125 GPM	<input type="checkbox"/>
150	150 GPM	<input type="checkbox"/>
200	200 GPM	<input type="checkbox"/>
250	250 GPM	<input type="checkbox"/>
300	300 GPM	<input type="checkbox"/>
350	350 GPM	<input type="checkbox"/>
400	400 GPM	<input type="checkbox"/>
450	450 GPM	<input type="checkbox"/>
500	500 GPM	<input type="checkbox"/>

Options (Select One or More)		
Size	Description	
-E	Extension	<input type="checkbox"/>
-HD	Heavy Duty (10,000 Lb.) Traffic Cover	<input type="checkbox"/>
-O	Inlet & Outlet	<input type="checkbox"/>
-SS	Stainless Steel	<input type="checkbox"/>
-THD	Threaded Connections	<input type="checkbox"/>

\* HD Option Requires Minimum 3" Ext.

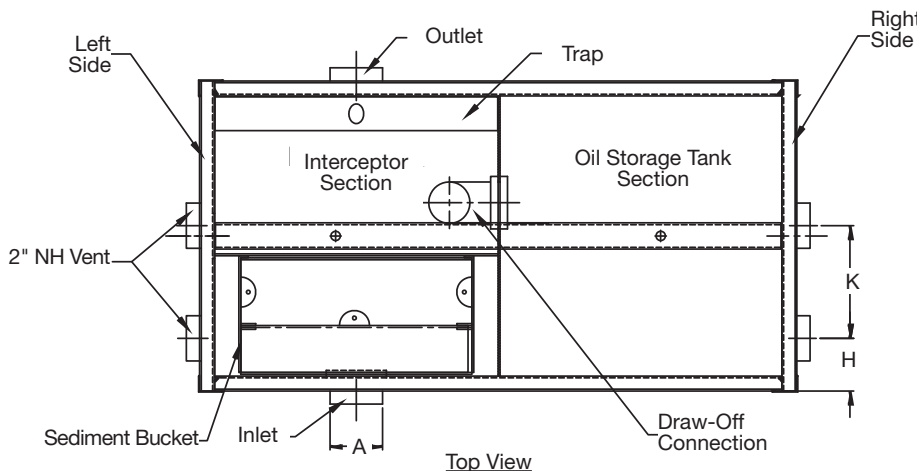

\*Note: See next page for Elevation, Side View & Dimensional Chart

### NOTICE

The information contained herein is not intended to replace the full product installation and safety information available or the experience of a trained product installer. You are required to thoroughly read all installation instructions and product safety information before beginning the installation of this product.

### NOTICE

Check local plumbing code for oil storage requirements prior to installation.

Watts product specifications in U.S. customary units and metric are approximate and are provided for reference only. For precise measurements, please contact Watts Technical Service. Watts reserves the right to change or modify product design, construction, specifications, or materials without prior notice and without incurring any obligation to make such changes and modifications on Watts products previously or subsequently sold.



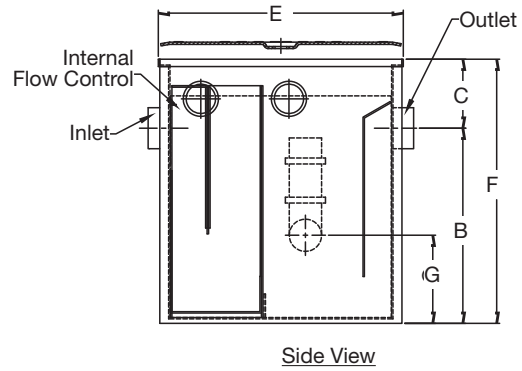
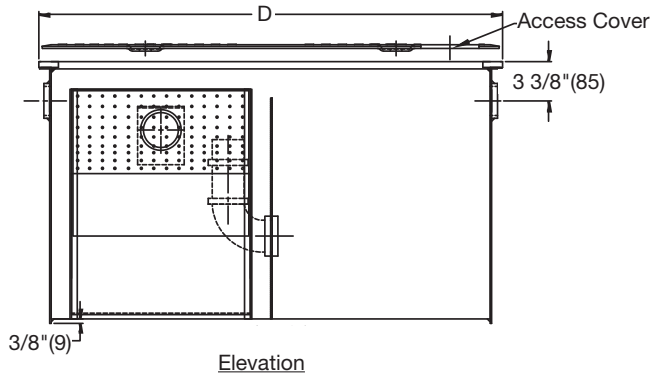

**Dimensional Chart**

Model No.	Rate GPM	Tank Oil Capacity USG	Combed Volume USG	A	B	C	D	E	F	G	H	K	J
				Inlet & Outlet	Base To Center	Top To Center	Length	Width	Height				
OI-10-ST	10	5	9	2"(51)	8.5"(216)	6"(152)	24"(610)	18"(457)	14.5"(368)	3"(76)	4.5"(114)	5.5"(140)	6"(152)
OI-15-ST	15	14	26	2"(51)	12.5"(318)	6"(152)	33.75"(857)	20.875"(530)	18.5"(470)	5"(127)	4.5"(114)	7.5"(191)	9"(229)
OI-20-ST	20	19	34	3"(76)	14.5"(368)	6"(152)	39.75"(1010)	20.875"(530)	20.5"(521)	6"(152)	4.5"(114)	7.5"(191)	10.4"(265)
OI-25-ST	25	22	40	3"(76)	16.5"(419)	6"(152)	39.75"(1010)	20.875"(530)	22.5"(572)	7"(178)	4.5"(114)	7.5"(191)	10.5"(265)
OI-35-ST	35	39	65	4"(102)	14.5"(368)	6"(152)	49.75"(1264)	32.875"(835)	20.5"(521)	6"(152)	12"(305)	6"(152)	13"(329)
OI-50-ST	50	51	90	4"(102)	18.5"(470)	6"(152)	49.75"(1264)	32.875"(835)	24.5"(622)	8"(203)	12"(305)	6"(152)	13"(329)
OI-75-ST	75	96	176	4"(102)	26.5"(673)	6"(152)	49.75"(1264)	40.875"(1038)	32.5"(826)	16"(406)	12"(305)	12"(305)	13"(329)
OI-100-ST	100	185	337	4"(102)	24"(610)	10"(254)	72"(1829)	54"(1372)	34"(864)	17.5"(445)	20"(508)	13"(330)	22.5"(572)
OI-150-ST	150	266	494	4"(102)	29"(737)	10"(254)	76"(1930)	60"(1524)	39"(991)	22.5"(572)	22"(559)	15"(381)	19"(483)
OI-200-ST	200	372	694	4"(102)	31"(787)	10"(254)	86"(2184)	69"(1735)	41"(1041)	24.5"(622)	26"(660)	18"(457)	22.5"(572)
OI-250-ST	250	505	951	4"(102)	37"(940)	10"(254)	90"(2286)	74"(1880)	47"(1194)	30"(762)	26"(660)	20"(508)	22.5"(572)
OI-300-ST	300	553	1011	6"(152)	38"(965)	10"(254)	96"(2438)	76"(1930)	48"(1219)	30.5"(775)	27"(686)	20"(508)	21.5"(546)
OI-350-ST	350	616	1129	6"(152)	39"(991)	10"(254)	100"(2540)	79"(2007)	49"(1245)	31.5"(800)	28"(711)	21"(533)	23.5"(597)
OI-400-ST	400	771	1423	6"(152)	42"(1067)	10"(254)	110"(2794)	83"(2108)	52"(1321)	34.5"(876)	30"(762)	23"(584)	22.75"(578)
OI-500-ST	500	1182	2222	6"(152)	53"(1346)	10"(254)	120"(3048)	91"(2311)	63"(1600)	45.5"(1156)	32"(815)	25"(635)	20.75"(527)



USA: Tel: (800) 338-2581 • Fax: (978) 248-3929 • Watts.com  
 Canada: Tel: (905) 332-4090 • Fax: (905) 332-7068 • Watts.ca  
 Latin America: Tel: (52) 81-1001-8600 • Watts.com