

For Commercial Applications

Job Name _____

Contractor _____

Job Location _____

Approval _____

Engineer _____

Contractor's P.O. No. _____

Approval _____

Representative _____

Tag _____

ISCA-141 Industry Standard Thin Wall Closet Carrier

Specification

Watts Drainage Products ISCA-141 *Industry Standard* single vertical thin wall water closet carrier with epoxy coated cast iron fitting, no hub waste and vent connections (specify size) epoxy coated cast iron patented compression seal faceplate assembly, epoxy coated cast iron foot supports with incremental measurements embossed onto legs to easily adjust height of carrier to most commonly used fixture requirements. Adjustable for standard and wheelchair height, adjustable ABS nipple with integral test cap and neoprene bowl gasket, plated hardware and chrome cap nuts. Carrier complies with requirements of ASME A112.6.1M up to a 500 lb. (227 kg.) static load.

Suffix	Options (Select One or More) Description	
-BF	Assy. for 4" C/L Back Outlet Bowl	<input type="checkbox"/>
-3	3"(76) NH Waste, 2"(51) NH Vent	<input type="checkbox"/>
-4-V2	4"(102) NH Waste, 2"(51) NH Vent	<input type="checkbox"/>
-4-V4	4"(102) NH Waste, 4"(102) NH Vent	<input type="checkbox"/>
-CI	Cast Iron Nipple	<input type="checkbox"/>
-M1	ABS Extended Nipple (Up to 24")	<input type="checkbox"/>
-M11	Tiling Frame	<input type="checkbox"/>
-M20	Flush Valve Support	<input type="checkbox"/>
-M23	2"(51) RH Auxiliary Inlet	<input type="checkbox"/>
-M24	2"(51) LH Auxiliary Inlet	<input type="checkbox"/>
-US	Buy American Compliant 	<input type="checkbox"/>

NOTICE

Anchor legs to concrete floor with minimum 1/2"(13) anchor bolts (by others).

Dual slotted carrier feet require one 1/2"(13) anchor bolt per foot.

X = 5 3/4"(146) Maximum with Standard Nipple

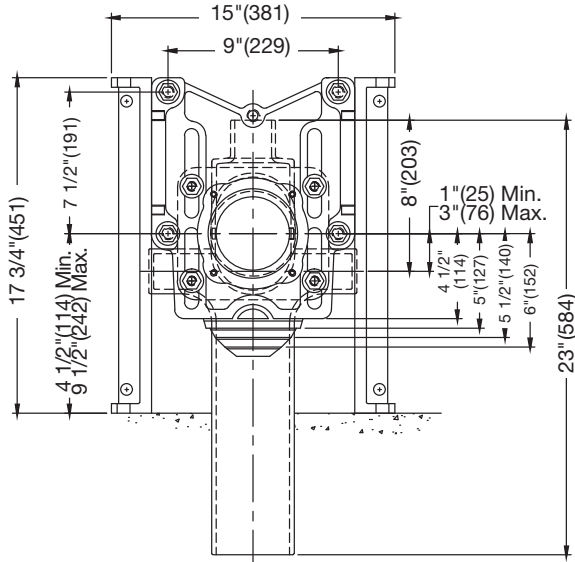
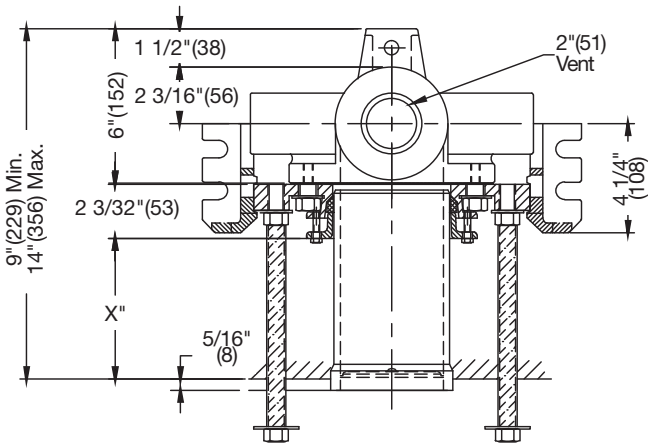

NOTICE

The information contained herein is not intended to replace the full product installation and safety information available or the experience of a trained product installer. You are required to thoroughly read all installation instructions and product safety information before beginning the installation of this product.

Watts product specifications in U.S. customary units and metric are approximate and are provided for reference only. For precise measurements, please contact Watts Technical Service. Watts reserves the right to change or modify product design, construction, specifications, or materials without prior notice and without incurring any obligation to make such changes and modifications on Watts products previously or subsequently sold.



USA: T: (800) 338-2581 • F: (978) 975-8350 • Watts.com
Canada: T: (905) 332-4090 • F: (905) 332-7068 • Watts.ca
Latin America: T: (52) 81-1001-8600 • Watts.com