

For Commercial Applications

Job Name _____
 Job Location _____
 Engineer _____
 Approval _____
 Tag _____

Contractor _____
 Approval _____
 Contractor's P.O. No. _____
 Representative _____

ISCA-133-L/R/2

Industry Standard Single Vertical 750 lb. Closet Carrier with Side Inlet(s)

Specification

Watts Drainage Products ISCA-133-L/R/2 *Industry Standard* single vertical adjustable water closet carrier with epoxy coated cast iron fitting, 4"(102) no hub waste and 2"(51) no hub vent connections, 4"(102) no hub side inlet(s), epoxy coated cast iron patented compression seal faceplate assembly, epoxy coated cast iron foot supports with incremental measurements embossed onto legs to easily adjust height of carrier to most commonly used fixture requirements. Adjustable neoprene bowl gasket, stainless steel support rods and hardware, and chrome plated cap nuts. Carrier complies with requirements of ASME A112.6.1M up to a 750 lb. (350 kg.) static load.

Options (Select One or More)	
Suffix	Description
-CI	Cast Iron Nipple <input type="checkbox"/>
-HS	Hub & Spigot Connections <input type="checkbox"/>
M11	Tiling Frame <input type="checkbox"/>
-M20	Flush Valve Support <input type="checkbox"/>
-US	Buy American Compliant <input type="checkbox"/>

NOTICE

All foot supports must be securely anchored to concrete floor with min. 1/2"(13) anchors with pull-out force of 500 lbs. (227 kg.). Rear anchor support must be securely anchored with min. 1/2" (13) anchors with pull-out force of 1000 lbs. (454 kg.). Dual slotted carrier feet require one 1/2"(13) anchor bolt per foot.

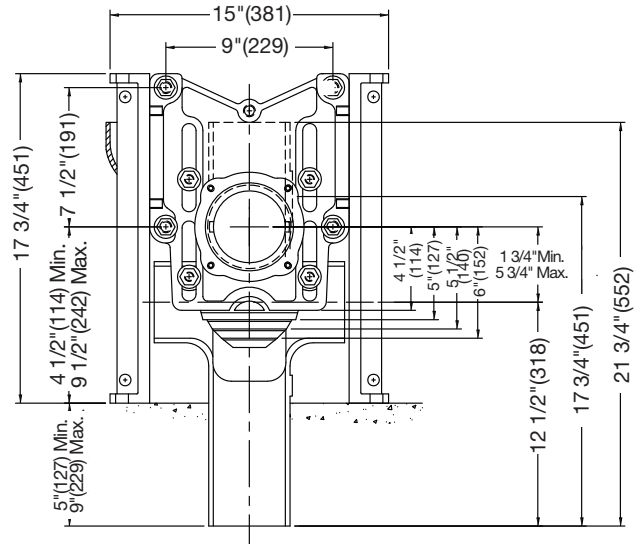
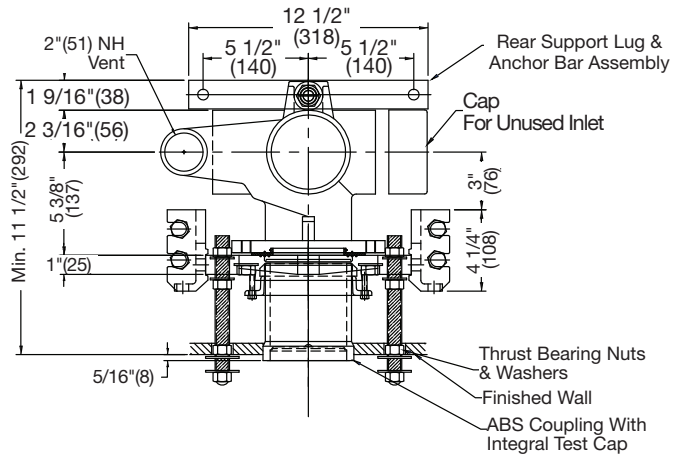

NOTICE

The information contained herein is not intended to replace the full product installation and safety information available or the experience of a trained product installer. You are required to thoroughly read all installation instructions and product safety information before beginning the installation of this product.

Watts product specifications in U.S. customary units and metric are approximate and are provided for reference only. For precise measurements, please contact Watts Technical Service. Watts reserves the right to change or modify product design, construction, specifications, or materials without prior notice and without incurring any obligation to make such changes and modifications on Watts products previously or subsequently sold.



USA: T: (800) 338-2581 • F: (978) 975-8350 • Watts.com
 Canada: T: (905) 332-4090 • F: (905) 332-7068 • Watts.ca
 Latin America: T: (52) 81-1001-8600 • Watts.com