



**ISCA-101-D**  
Tag: \_\_\_\_\_

**Industry Standard  
Back-To-Back Horizontal  
Adjustable Closet Carrier**

**SPECIFICATION:** Watts Drainage Products ISCA-101-D *Industry Standard* back-to-back horizontal adjustable water closet carrier with epoxy coated cast iron fitting, 4"(102) no hub waste and 2"(51) no hub vent connections, epoxy coated cast iron patent pending compression seal faceplate assembly, epoxy coated cast iron foot supports adjustable for standard and wheelchair height, adjustable ABS nipple with integral test cap and neoprene bowl gasket, plated hardware and chrome cap nuts.

Options (Select One or More)		
Suffix	Description	
-36	36" Long Barrel Fitting	<input type="checkbox"/>
CA-100-EXT	Aux. Support System w/Extended Nipple	<input type="checkbox"/>
-M1	ABS Extended Nipple (Up to 24")	<input type="checkbox"/>
-M3	Galvanized Steel Nipple 7"	<input type="checkbox"/>
-M11	Tiling Frame	<input type="checkbox"/>
-M20	Flush Valve Support	<input type="checkbox"/>

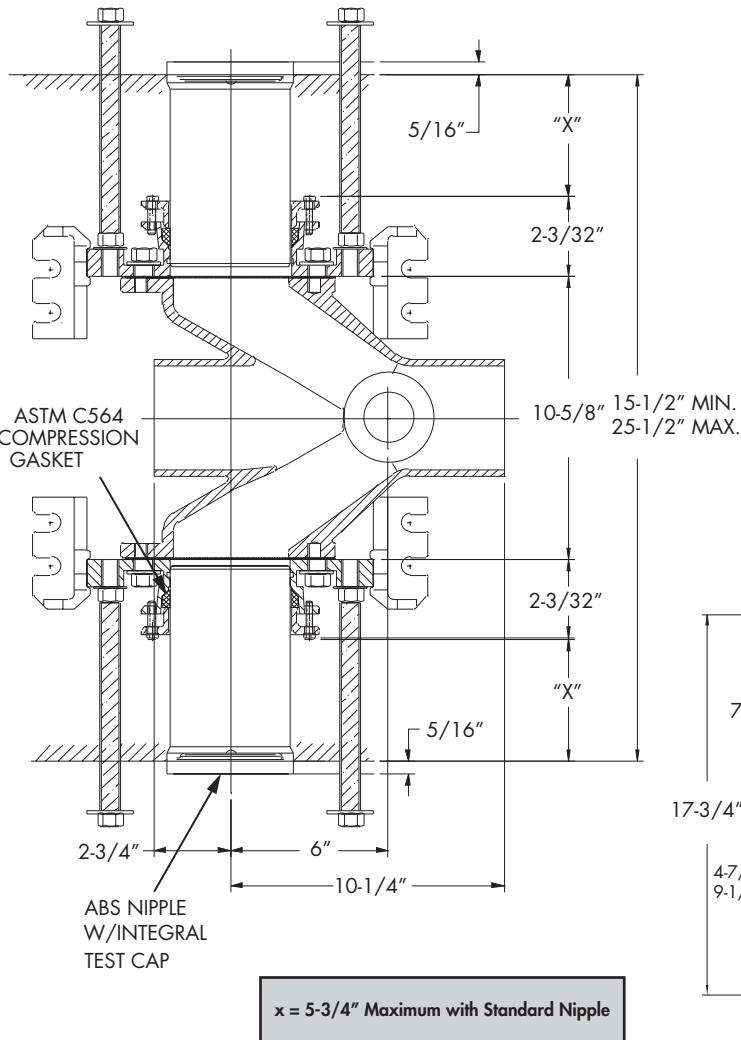

**NOTICE**

Siphon jet (4 bolt) arrangement shown. Invert faceplate assembly for blow-out (3 bolt) bowls.

Anchor legs to concrete floor with minimum 1/2" lag bolts (by others).

**NOTICE**

The information contained herein is not intended to replace the full product installation and safety information available or the experience of a trained product installer. You are required to thoroughly read all installation instructions and product safety information before beginning the installation of this product.

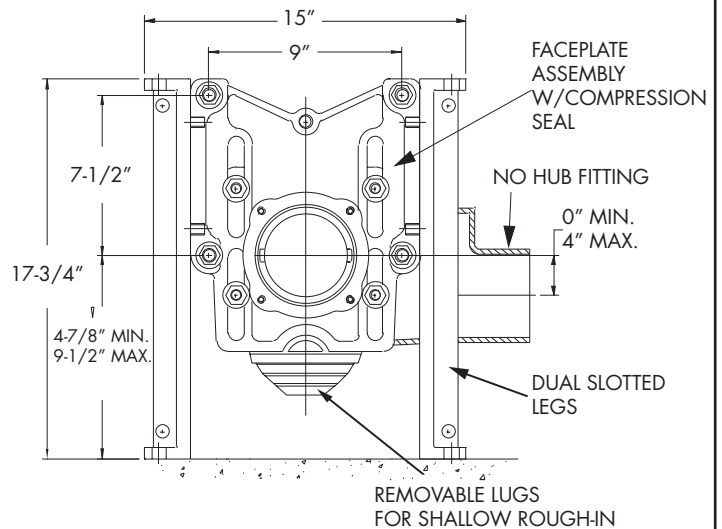

Job Name \_\_\_\_\_

Contractor \_\_\_\_\_

Job Location \_\_\_\_\_

Contractor's P.O. No. \_\_\_\_\_

Engineer \_\_\_\_\_

Representative \_\_\_\_\_

Watts product specifications in U.S. customary units and metric are approximate and are provided for reference only. For precise measurements, please contact Watts Technical Service. Watts reserves the right to change or modify product design, construction, specifications, or materials without prior notice and without incurring any obligation to make such changes and modifications on Watts products previously or subsequently sold.

**USA:** Tel: (800) 338-2581 • Fax: (828) 248-3929 • Watts.com  
**Canada:** Tel: (905) 332-4090 • Fax: (905) 332-7068 • Watts.ca  
**Latin America:** Tel: (52) 81-1001-8600 • Fax: (52) 81-8000-7091 • Watts.com



A Watts Water Technologies Company