

For Commercial Applications

Job Name _____
 Job Location _____
 Engineer _____
 Approval _____
 Tag _____

Contractor _____
 Approval _____
 Contractor's P.O. No. _____
 Representative _____

ISCA-101-D-BF

Industry Standard Back-To-Back Horizontal Carrier for Floor Mounted Back Outlet Bowl

Specification

Watts Drainage ISCA-101-D-BF *Industry Standard* back-to-back horizontal water closet carrier for floor mounted back outlet bowl, with epoxy coated cast iron fitting, 4"(102) no hub waste and 2"(51) no hub vent connections, epoxy coated cast iron foot supports with incremental measurements embossed onto legs to easily adjust height of carrier to most commonly used fixture requirements. Patented compression seal faceplate assembly, ABS nipple with integral test cap and neoprene bowl gasket, plated hardware and chrome cap nuts.

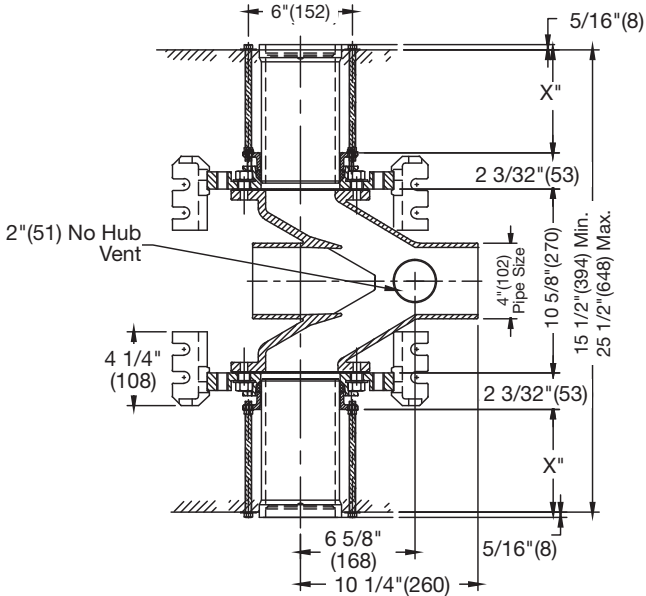

Options (Select One or More)		
Suffix	Description	
-3	3" No Hub Fitting	<input type="checkbox"/>
-36	36" Long Barrel Fitting	<input type="checkbox"/>
-CI	Cast Iron Nipple	<input type="checkbox"/>
-HS	Hub & Spigot Connections	<input type="checkbox"/>
-US	Buy American Compliant	<input type="checkbox"/>

NOTICE

Anchor legs to concrete floor with minimum 1/2"(13) anchor bolts (by others).
 Dual slotted carrier feet require one 1/2"(13) anchor bolt per foot.

x = 5 3/4"(146) Maximum with Standard Nipple

NOTICE

The information contained herein is not intended to replace the full product installation and safety information available or the experience of a trained product installer. You are required to thoroughly read all installation instructions and product safety information before beginning the installation of this product.

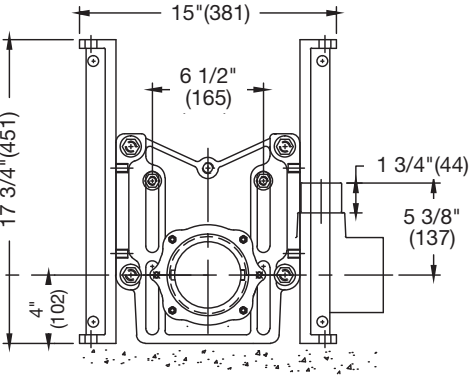

Watts product specifications in U.S. customary units and metric are approximate and are provided for reference only. For precise measurements, please contact Watts Technical Service. Watts reserves the right to change or modify product design, construction, specifications, or materials without prior notice and without incurring any obligation to make such changes and modifications on Watts products previously or subsequently sold.

