



GRD-730

Tag: \_\_\_\_\_

### Green Roof Large Multi-Level Planter Drain

**SPECIFICATION:** Watts Drainage GRD-730 epoxy coated cast iron green roof multi-level planter drain with bottom flashing clamp and stainless steel screened aluminum dome, perforated ABS standpipe, upper self-locking stainless steel screened aluminum dome, and no hub (standard) outlet.

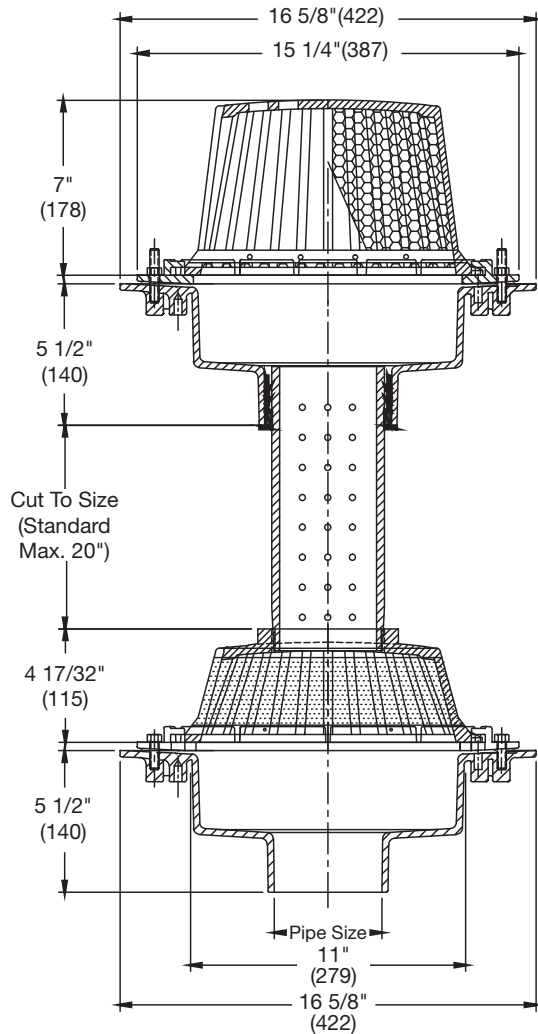

Pipe Sizing (Select One)		
Suffix	Description	
2	2"(51) Pipe Size (NH Only)	<input type="checkbox"/>
3	3"(76) Pipe Size	<input type="checkbox"/>
4	4"(102) Pipe Size	<input type="checkbox"/>
5	5"(127) Pipe Size (NH Only)	<input type="checkbox"/>
6	6"(152) Pipe Size	<input type="checkbox"/>
8	8"(203) Pipe Size	<input type="checkbox"/>
10	10"(254) Pipe Size (NH Only)	<input type="checkbox"/>

Outlet Type (Select One)		
Suffix	Description	
NH	No Hub (MJ)	<input type="checkbox"/>
P	Push On	<input type="checkbox"/>
X	Inside Caulk	<input type="checkbox"/>

Options (Select One or More)		
Suffix	Description	
-5	Sediment Bucket	<input type="checkbox"/>
-6	Vandal Proof Top	<input type="checkbox"/>
-13	Galvanized	<input type="checkbox"/>
-B	Sump Receiver	<input type="checkbox"/>
-D	Underdeck Clamp	<input type="checkbox"/>
-F	Deck Flange/Adj. Extension	<input type="checkbox"/>
-US	Buy American Compliant	<input type="checkbox"/>

Deck opening 14-1/2"(368) with sump receiver 18"(457)

#### NOTICE

The information contained herein is not intended to replace the full product installation and safety information available or the experience of a trained product installer. You are required to thoroughly read all installation instructions and product safety information before beginning the installation of this product

Job Name \_\_\_\_\_

Contractor \_\_\_\_\_

Job Location \_\_\_\_\_

Contractor's P.O. No. \_\_\_\_\_

Engineer \_\_\_\_\_

Representative \_\_\_\_\_

Watts product specifications in U.S. customary units and metric are approximate and are provided for reference only. For precise measurements, please contact Watts Technical Service. Watts reserves the right to change or modify product design, construction, specifications, or materials without prior notice and without incurring any obligation to make such changes and modifications on Watts products previously or subsequently sold.

USA: Tel: (800) 338-2581 • Fax: (828) 248-3929 • Watts.com  
Canada: Tel: (905) 332-4090 • Fax: (905) 332-7068 • Watts.ca  
Latin America: Tel: (52) 81-1001-8600 • Fax: (52) 81-8000-7091 • Watts.com



A Watts Water Technologies Company