

SPECIFICATION: Watts Drainage Products FD-940 epoxy coated all cast iron floor drain with deep body with serrated clamping flange, combined body collar and flashing clamp device, adjustable collar and non-tilt 8"(203) diameter epoxy coated ductile iron (standard) tractor grate.

Order Code: **FD-94** - - -

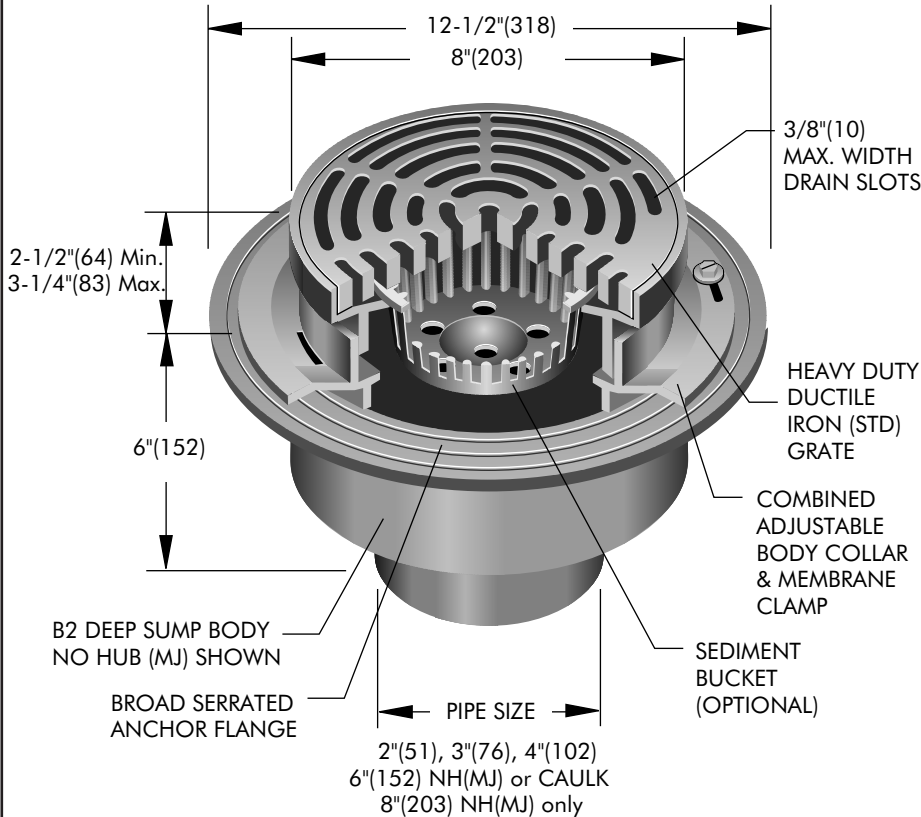

Ex. FD-942P-4

Pipe Sizing (Select One)		
Suffix	Description	
2	2"(51) Pipe Size	<input type="checkbox"/>
3	3"(76) Pipe Size	<input type="checkbox"/>
4	4"(102) Pipe Size	<input type="checkbox"/>
6	6"(152) Pipe Size	<input type="checkbox"/>
8	8"(203) Pipe Size	<input type="checkbox"/>

Outlet Type (Select One)		
Suffix	Description	
NH	No Hub (MJ)	<input type="checkbox"/>
P	Push On	<input type="checkbox"/>
T	Threaded Outlet	<input type="checkbox"/>
X	Inside Caulk	<input type="checkbox"/>

Strainer (Select One)		
Suffix	Description	
-1	8"(203) Diameter, Nickel Bronze	<input type="checkbox"/>
-3	8"(203) Diameter, Stainless Steel	<input type="checkbox"/>
-4	8"(203) Diameter, Ductile Iron	<input type="checkbox"/>

Options (Select One or More)		
Suffix	Description	
-5	Sediment Bucket	<input type="checkbox"/>
-6	Vandal Proof	<input type="checkbox"/>
-10	Secured Top c/w Phillips Screws	<input type="checkbox"/>
-12	Galvanized Top	<input type="checkbox"/>
-13	All Galvanized	<input type="checkbox"/>
-113M	Special Epoxy from 3M Range	<input type="checkbox"/>
-D	Underdeck Clamp	<input type="checkbox"/>
-B	Sump Receiver	<input type="checkbox"/>
-F4-50	4" Round Cast Iron Funnel	<input type="checkbox"/>
-F4-1	4" Round Nickel Bronze Funnel	<input type="checkbox"/>
-F6-50	6" Round Cast Iron Funnel	<input type="checkbox"/>
-F6-1	6" Round Nickel Bronze Funnel	<input type="checkbox"/>
-G-50	4x9" Oval Cast Iron Funnel	<input type="checkbox"/>
-G-1	4x9" Oval Nickel Bronze Funnel	<input type="checkbox"/>
-Z	Elastomeric Flange	<input type="checkbox"/>

Optional Body Material (NH Only)		
Suffix	Description	
-60	PVC Body w/Socket Outlet	<input type="checkbox"/>
-61	ABS Body w/Socket Outlet	<input type="checkbox"/>

Suffix	Load Rating	Free Area Sq. In.
-1	*XHD	15
-3	*XHD	15
-4	*XHD	15

* The load classifications are in accordance with the American National Standards ASME A112.21.1M ASME Ratings are as follows:
XHD - Safe Live Load 7500-10000 lbs.(3375-4500kg)
The above categories are given as a guide only.
Please consult factory.

Job Name _____ Contractor _____

Job Location _____ Contractor's P.O. No. _____

Engineer _____ Representative _____

WATTS Drainage reserves the right to modify or change product design or construction without prior notice and without incurring any obligation to make similar changes and modifications to products previously or subsequently sold. See your WATTS Drainage representative for any clarification. Dimensions are subject to manufacturing tolerances