

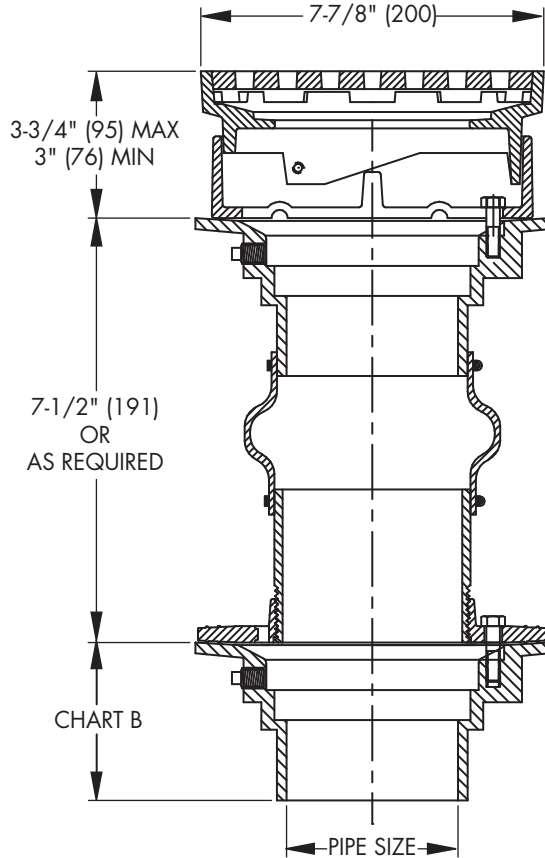

FD-620
Tag: _____

**Unfinished Area
Isolation Drain**

SPECIFICATION: Watts Drainage FD-620 epoxy coated cast iron isolation drain with epoxy coated cast iron upper and lower bodies, reversible membrane clamps with primary and secondary weepholes, 8" (203) diameter adjustable top with heel proof ductile iron grate, neoprene movement compensator coupling, and no hub (standard) outlet.



Pipe Sizing (Select One)		
Suffix	Description	
2	2" (51) Pipe Size	<input type="checkbox"/>
3	3" (76) Pipe Size	<input type="checkbox"/>
4	4" (102) Pipe Size	<input type="checkbox"/>
6	6" (152) Pipe Size (NH Only)	<input type="checkbox"/>

Outlet Type (Select One)		
Suffix	Description	
NH	No Hub (MJ)	<input type="checkbox"/>
P	Push On	<input type="checkbox"/>
T	Threaded Outlet	<input type="checkbox"/>
X	Inside Caulk	<input type="checkbox"/>

Options (Select One or More)		
Suffix	Description	
-1	Nickel Bronze Top	<input type="checkbox"/>
-5	Sediment Bucket	<input type="checkbox"/>
-6	Vandal Proof	<input type="checkbox"/>
-7	Trap Primer Tapping	<input type="checkbox"/>
-8	Backwater Valve (2,3,4" Only)	<input type="checkbox"/>
-13	Galvanized Body	<input type="checkbox"/>
-21	Secondary Strainer	<input type="checkbox"/>
-34	Closure Plug	<input type="checkbox"/>
-F4-50	4" Round Cast Iron Funnel	<input type="checkbox"/>
-F4-1	4" Round Nickel Bronze Funnel	<input type="checkbox"/>
-F6-1	6" Round Nickel Bronze Funnel	<input type="checkbox"/>
-G-50	4x9" Oval Cast Iron Funnel	<input type="checkbox"/>
-G-1	4x9" Oval Nickel Bronze Funnel	<input type="checkbox"/>
-SO	Side Outlet	<input type="checkbox"/>
-US	Buy American Compliant	<input type="checkbox"/>
-Z	Elastomeric Flange	<input type="checkbox"/>

Optional Body Material		
Suffix	Description	
-60	PVC Body w/Socket Outlet	<input type="checkbox"/>
-61	ABS Body w/Socket Outlet	<input type="checkbox"/>

Chart B

	Std.	P	T	X	60/61
Pipe Size	No Hub	Push On	Female Thread	Inside Caulk	PVC/ABS
2" (51)	3-5/8" (92)	4-1/4" (108)	4-1/4" (108)	4-1/4" (108)	3-3/4" (95)
3" (76)	3-5/8" (92)	4-1/4" (108)	4-1/4" (108)	4-1/4" (108)	3-5/8" (92)
4" (102)	3-5/8" (92)	4-1/4" (108)	4-1/4" (108)	4-1/4" (108)	3-7/8" (94)
6" (152)	3-1/2" (89)				

Load Rating & Free Area

Load Rating	Free Area Sq. In.
*XHD	18

* The load classifications are in accordance with the American National Standards ASME A112.21.1M ASME Ratings are as follows:
XHD - Safe Live Load 7500-10000 lbs. (3375-4500kg)
The above categories are given as a guide only. Please consult factory.

Job Name _____ Contractor _____

Job Location _____ Contractor's P.O. No. _____

Engineer _____ Representative _____

WATTS Drainage reserves the right to modify or change product design or construction without prior notice and without incurring any obligation to make similar changes and modifications to products previously or subsequently sold. See your WATTS Drainage representative for any clarification. Dimensions are subject to manufacturing tolerances.



Specification Drainage Products

USA: 100 Watts Road, Spindale, NC, 28160-2298; TEL: 828-288-2179 TOLL-FREE: 1-800-338-2581 www.watts.com