

SPECIFICATION: Watts Drainage Products FD-570 fabricated stainless steel kettle drain shall be regularly furnished with 3/16"x1"(21x25) bars heavy duty reinforced (non bacteria free) stainless steel loose set grate.

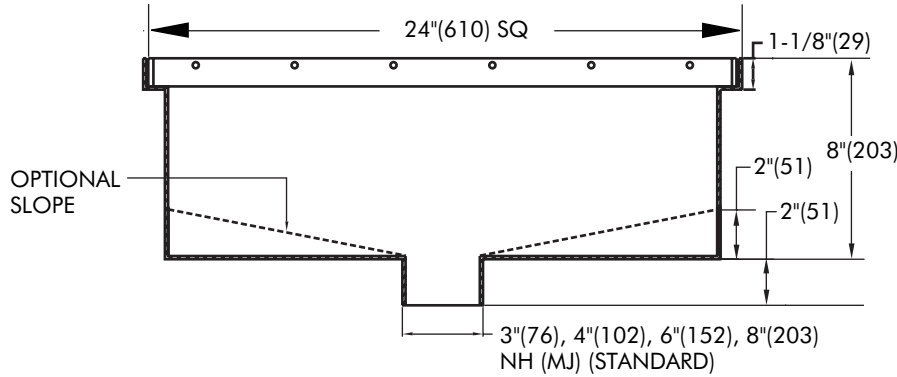

Order Code: FD-57 -

Ex. FD-574-5

Pipe Sizing (Select One)		
Suffix	Description	
3	3"(76) Pipe Size	<input type="checkbox"/>
4	4"(102) Pipe Size	<input type="checkbox"/>
6	6"(152) Pipe Size	<input type="checkbox"/>
8	8"(203) Pipe Size	<input type="checkbox"/>

Options (Select One or More)		
Suffix	Description	
-5	Sediment Bucket	<input type="checkbox"/>
-DM	Dome Bottom Strainer	<input type="checkbox"/>
-F	Anchor Flange	<input type="checkbox"/>
-FC	Flange Clamp	<input type="checkbox"/>
-S	Bottom Slope	<input type="checkbox"/>

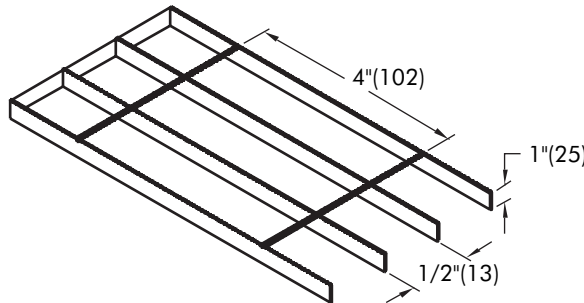

Job Name _____ Contractor _____

Job Location _____ Contractor's P.O. No. _____

Engineer _____ Representative _____

WATTS Drainage reserves the right to modify or change product design or construction without prior notice and without incurring any obligation to make similar changes and modifications to products previously or subsequently sold. See your WATTS Drainage representative for any clarification. Dimensions are subject to manufacturing tolerances.