



**FD-470-F**

Tag: \_\_\_\_\_

**15"x15" Shallow Body Promenade Drain**

**SPECIFICATION:** Watts Drainage Products FD-470-F epoxy coated cast iron promenade drain with flashing flange, weepholes, 15-5/8"x15-5/8"(397x397) solid nickel bronze grate and no hub outlet.

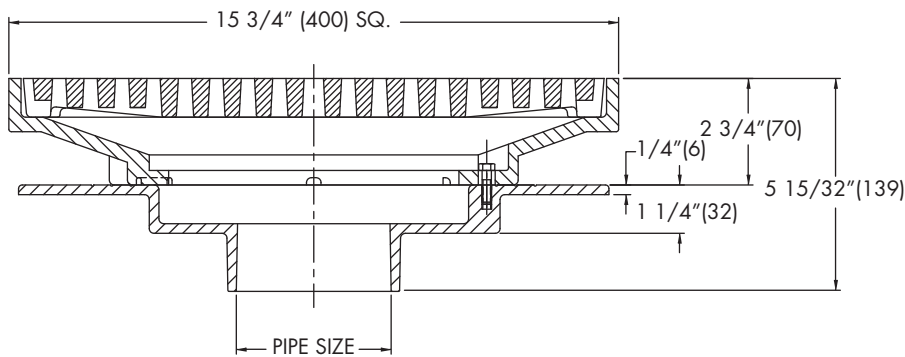

Pipe Sizing (Select One)		
Size	Description	
2	2"(51) Pipe Size	<input type="checkbox"/>
3	3"(76) Pipe Size	<input type="checkbox"/>
4	4"(102) Pipe Size	<input type="checkbox"/>
6	6"(152) Pipe Size	<input type="checkbox"/>
8	8"(203) Pipe Size	<input type="checkbox"/>

Outlet Type (Select One)		
Suffix	Description	
NH	No Hub (MJ)	<input type="checkbox"/>
P	Push-On	<input type="checkbox"/>
T	Threaded Outlet	<input type="checkbox"/>
X	Inside Caulk	<input type="checkbox"/>

Grate (Select One)		
Suffix	Description	
F-1	15"x15"(381x381) Solid Nickel Bronze	<input type="checkbox"/>
F-3	15"x15"(381x381) S.S. Veneer	<input type="checkbox"/>
F-4	15"x15"(381x381) Ductile Iron	<input type="checkbox"/>

Options (Select One)		
Suffix	Description	
-5	Sediment Bucket	<input type="checkbox"/>
-6	Vandal Proof	<input type="checkbox"/>
-7	Trap Primer Tapping	<input type="checkbox"/>
-8	Backwater Valve (3"/4" Only)	<input type="checkbox"/>
-9	Hinged Grate	<input type="checkbox"/>
-10	Secured Top c/w Phillips Screws	<input type="checkbox"/>
-12	Hot Dipped Galvanized	<input type="checkbox"/>
-13	Painted Galvanized	<input type="checkbox"/>
-26	Hinged Locking Grate	<input type="checkbox"/>
-34	Closure Plug	<input type="checkbox"/>
-113M	Special Epoxy from 3M Range	<input type="checkbox"/>
-SO	Side Outlet	<input type="checkbox"/>
-Z	Elastomeric Flange	<input type="checkbox"/>

**NOTICE**

The load classifications are in accordance with the American National Standards ASME A112.21.1M ASME Ratings are as follows:  
 XHD - Safe Live Load 7500-10000 lbs.(3375-4500kg)  
 The above categories are given as a guide only.  
 Please consult factory.

Suffix	Load Rating	Free Area Sq. In.
F-1	*XHD	57
F-3	*XHD	57
F-4	*XHD	57

Job Name \_\_\_\_\_

Contractor \_\_\_\_\_

Job Location \_\_\_\_\_

Contractor's P.O. No. \_\_\_\_\_

Engineer \_\_\_\_\_

Representative \_\_\_\_\_

Watts product specifications in U.S. customary units and metric are approximate and are provided for reference only. For precise measurements, please contact Watts Technical Service. Watts reserves the right to change or modify product design, construction, specifications, or materials without prior notice and without incurring any obligation to make such changes and modifications on Watts products previously or subsequently sold.



**USA:** Tel: (800) 338-2581 • Fax: (828) 248-3929 • Watts.com  
**Canada:** Tel: (905) 332-4090 • Fax: (905) 332-7068 • Watts.ca  
**Latin America:** Tel: (52) 81-1001-8600 • Fax: (52) 81-8000-7091 • Watts.com