

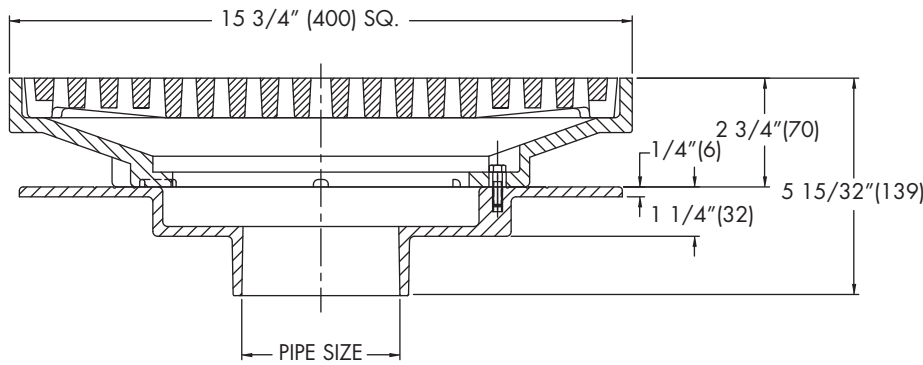

FD-470-F-1
 Tag: _____

15"x15" Shallow Body Promenade Drain

SPECIFICATION: Watts Drainage FD-470-F-1 epoxy coated cast iron promenade drain with flashing flange, weepholes, 15-5/8"x15-5/8"(397x397) square solid nickel bronze fixed top with heel-proof grate, and no hub outlet.



Pipe Sizing (Select One)		
Suffix	Description	
4	4"(102) Pipe Size	<input type="checkbox"/>
6	6"(152) Pipe Size	<input type="checkbox"/>
8	8"(203) Pipe Size	<input type="checkbox"/>

Outlet Type (Select One)		
Suffix	Description	
NH	No Hub (MJ)	<input type="checkbox"/>

Options (Select One or More)		
Suffix	Description	
-B	Sump Reciever	<input type="checkbox"/>
-D	Underdeck Clamp	<input type="checkbox"/>
-S	Sediment Bucket	<input type="checkbox"/>
-6	Vandal Proof	<input type="checkbox"/>

Load Rating & Free Area

Load Rating	Free Area Sq. In.
*XHD	57

* The load classifications are in accordance with the American National Standards ASME A112.21.1M ASME Ratings are as follows:
 XHD - Safe Live Load 7500-10000 lbs.(3375-4500kg)
 The above categories are given as a guide only. Please consult factory.

Job Name _____

Contractor _____

Job Location _____

Contractor's P.O. No. _____

Engineer _____

Representative _____

Watts product specifications in U.S. customary units and metric are approximate and are provided for reference only. For precise measurements, please contact Watts Technical Service. Watts reserves the right to change or modify product design, construction, specifications, or materials without prior notice and without incurring any obligation to make such changes and modifications on Watts products previously or subsequently sold.



A Watts Water Technologies Company

USA: Tel: (800) 338-2581 • Fax: (828) 248-3929 • Watts.com
Canada: Tel: (905) 332-4090 • Fax: (905) 332-7068 • Watts.ca
Latin America: Tel: (52) 81-1001-8600 • Fax: (52) 81-8000-7091 • Watts.com