

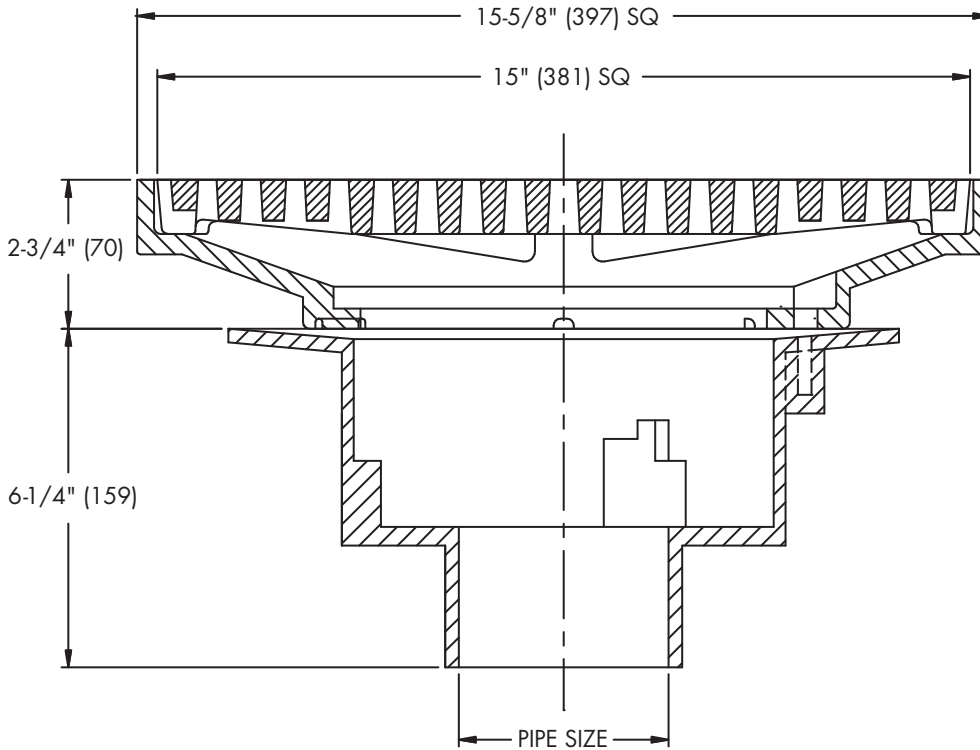

FD-450-F
Tag: _____

**Area Drain with
15"x15" Fixed Top**

SPECIFICATION: Watts Drainage FD-450-F epoxy coated cast iron area drain with anchor flange, weepholes, 15-5/8"x15-5/8"(397x397) square fixed top with heel proof ductile iron grate, and no hub (standard) outlet.



NOTICE

Load Rating & Free Area

Load Rating	Free Area Sq. In.
*XHD	57

The load classifications are in accordance with the American National Standards ASME A112.21.1M ASME Ratings are as follows:
XHD - Safe Live Load 7500-10000 lbs.(3375-4500kg)
The above categories are given as a guide only. Please consult factory.

Components

Pipe Sizing (Select One)

Suffix	Description	
2	2"(51) Pipe Size	<input type="checkbox"/>
3	3"(76) Pipe Size	<input type="checkbox"/>
4	4"(102) Pipe Size	<input type="checkbox"/>
5	5"(152) Pipe Size (NH Only)	<input type="checkbox"/>
6	6"(152) Pipe Size	<input type="checkbox"/>
8	8"(203) Pipe Size (NH Only)	<input type="checkbox"/>

Outlet Type (Select One)

Suffix	Description	
NH	No Hub (MJ)	<input type="checkbox"/>
P	Push On	<input type="checkbox"/>
T	Threaded Outlet	<input type="checkbox"/>
X	Inside Caulk	<input type="checkbox"/>

Options (Select One or More)

Suffix	Description	
-1	Nickel Bronze Top	<input type="checkbox"/>
-5	Sediment Bucket	<input type="checkbox"/>
-6	Vandal Proof	<input type="checkbox"/>
-7	Trap Primer Tapping	<input type="checkbox"/>
-8	Backwater Valve (2, 3, 4" Only)	<input type="checkbox"/>
-9	Hinged Grate	<input type="checkbox"/>
-13	All Galvanized	<input type="checkbox"/>
-21	Secondary Strainer	<input type="checkbox"/>
-34	Closure Plug	<input type="checkbox"/>
-F4-50	4" Round Cast Iron Funnel	<input type="checkbox"/>
-F4-1	4" Round Nickel Bronze Funnel	<input type="checkbox"/>
-F6-1	6" Round Nickel Bronze Funnel	<input type="checkbox"/>
-G-50	4"x9" Oval Cast Iron Funnel	<input type="checkbox"/>
-G-1	4"x9" Oval Nickel Bronze Funnel	<input type="checkbox"/>
-SB	Shallow Body 2-3/4" Deep (3", 4", 6" NH/P, 8" NH)	<input type="checkbox"/>
-SO	Side Outlet (2, 3, 4" Only)	<input type="checkbox"/>
-US	Buy American Compliant	<input type="checkbox"/>

Optional Body Material

Suffix	Description	
-60	PVC Body (2, 3, 4, 6" Only)	<input type="checkbox"/>
-61	ABS Body (2, 3, 4" Only)	<input type="checkbox"/>

Job Name _____

Contractor _____

Job Location _____

Contractor's P.O. No. _____

Engineer _____

Representative _____

Watts product specifications in U.S. customary units and metric are approximate and are provided for reference only. For precise measurements, please contact Watts Technical Service. Watts reserves the right to change or modify product design, construction, specifications, or materials without prior notice and without incurring any obligation to make such changes and modifications on Watts products previously or subsequently sold.

USA: Tel: (800) 338-2581 • Fax: (828) 248-3929 • Watts.com
Canada: Tel: (905) 332-4090 • Fax: (905) 332-7068 • Watts.ca
Latin America: Tel: (52) 81-1001-8600 • Fax: (52) 81-8000-7091 • Watts.com



A Watts Water Technologies Company