



FD-450-AF

Tag: _____

Area Drain with 15" Square Adjustable Top

Components:



SPECIFICATION: Watts Drainage Products FD-450-AF epoxy coated cast iron floor drain with deep sump body, wide serrated anchor flange, weepholes, adjustable collar and 15-5/8"x15-5/8"(397x397) square epoxy coated ductile iron (standard) tractor grate.

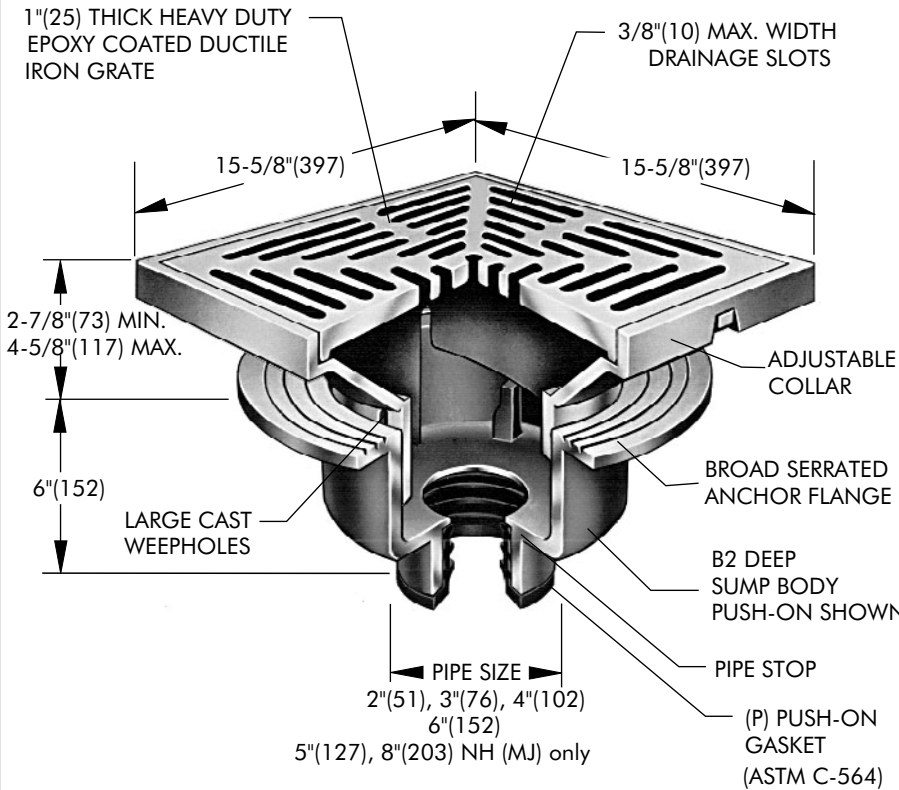

Order Code: FD-45 - -

Ex. FD-452P-AF-1

Pipe Sizing (Select One)		
Suffix	Description	
2	2"(51) Pipe Size	<input type="checkbox"/>
3	3"(76) Pipe Size	<input type="checkbox"/>
4	4"(102) Pipe Size	<input type="checkbox"/>
5	5"(127) Pipe Size	<input type="checkbox"/>
6	6"(152) Pipe Size	<input type="checkbox"/>
8	8"(203) Pipe Size	<input type="checkbox"/>

Outlet Type (Select One)		
Suffix	Description	
NH	No Hub (MJ)	<input type="checkbox"/>
P	Push On	<input type="checkbox"/>
T	Threaded Outlet	<input type="checkbox"/>
X	Inside Caulk	<input type="checkbox"/>

Grate (Select One)		
Suffix	Description	
AF-3	Stainless Steel Veneer	<input type="checkbox"/>
AF-4	Ductile Iron	<input type="checkbox"/>

Options (Select One or More)		
Suffix	Description	
-5	Sediment Bucket	<input type="checkbox"/>
-6	Vandal Proof	<input type="checkbox"/>
-7	Trap Primer Tapping	<input type="checkbox"/>
-8	Backwater Valve (3" / 4" Only)	<input type="checkbox"/>
-9	Hinged Grate	<input type="checkbox"/>
-10	Secured Top c/w Phillips screws	<input type="checkbox"/>
-12	Galvanized Top	<input type="checkbox"/>
-13	All Galvanized	<input type="checkbox"/>
-15	Adj. Extension (4" to 5-5/8")	<input type="checkbox"/>
-26	Hinged Locking Grate	<input type="checkbox"/>
-34	Closure Plug	<input type="checkbox"/>
-113M	Special Epoxy from 3M Range	<input type="checkbox"/>
-Z	Elastomeric Flange	<input type="checkbox"/>

Load Rating & Free Area

Suffix	Load Rating	Free Area Sq. In.
AF-3	*XHD	57
AF-4	*XHD	57

* The load classifications are in accordance with the American National Standards ASME A112.21.1M ASME Ratings are as follows:
XHD - Safe Live Load 7500-10000 lbs.(3375-4500kg)
The above categories are given as a guide only.
Please consult factory.

Job Name _____ Contractor _____

Job Location _____ Contractor's P.O. No. _____

Engineer _____ Representative _____

WATTS Drainage reserves the right to modify or change product design or construction without prior notice and without incurring any obligation to make similar changes and modifications to products previously or subsequently sold. See your WATTS Drainage representative for any clarification. Dimensions are subject to manufacturing tolerances.



CANADA: 5435 North Service Road, Burlington, ON, L7L 5H7 TEL: 905-332-6718 TOLL-FREE: 1-888-208-8927 Website: www.wattsdrainage.ca

