

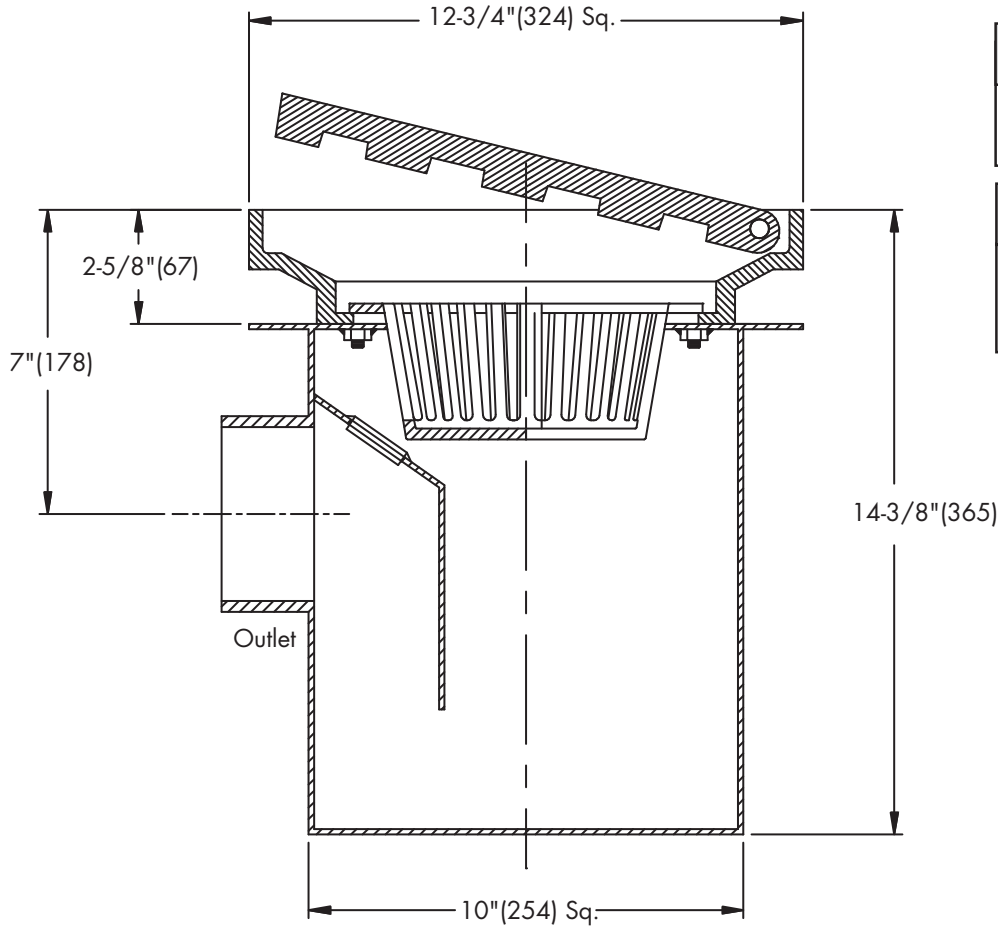

FD-430
Tag: _____

Side Outlet Area Drain with Hinged Grate

SPECIFICATION: Watts Drainage FD-430 epoxy coated steel side outlet area drain with anchor flange, 12-3/4"x12-3/4"(324x324) square epoxy coated heel proof ductile iron hinged grate, integral trap with cleanout plug, sediment bucket, and no hub (standard) outlet.



Pipe Sizing (Select One)		
Suffix	Description	
2	2"(51) Pipe Size	<input type="checkbox"/>
3	3"(76) Pipe Size	<input type="checkbox"/>
4	4"(102) Pipe Size	<input type="checkbox"/>

Options (Select One or More)		
Suffix	Description	
-1	Nickel Bronze Top	<input type="checkbox"/>
-T	Threaded Outlet	<input type="checkbox"/>
-6	Vandal Proof Grate	<input type="checkbox"/>
-US	Buy American Compliant	<input type="checkbox"/>

Load Rating & Free Area

Load Rating	Free Area Sq. In.
*XHD	41

* The load classifications are in accordance with the American National Standards ASME A112.21.1M ASME Ratings are as follows:
XHD - Safe Live Load 7500-10000 lbs.(3375-4500kg)
The above categories are given as a guide only.
Please consult factory.

Job Name _____ Contractor _____

Job Location _____ Contractor's P.O. No. _____

Engineer _____ Representative _____

WATTS Drainage reserves the right to modify or change product design or construction without prior notice and without incurring any obligation to make similar changes and modifications to products previously or subsequently sold. See your WATTS Drainage representative for any clarification. Dimensions are subject to manufacturing tolerances.



Specification Drainage Products

USA: 100 Watts Road, Spindale, NC, 28160-2298; TEL: 828-288-2179 TOLL-FREE: 1-800-338-2581 www.watts.com