



# FD-340-Y-SET

Tag: \_\_\_\_\_

## Area Drain with 12" Round Fixed Top, Grate Supported by Bucket

**SPECIFICATION:** Watts Drainage Products FD-340-Y-SET epoxy coated cast iron area drain with anchor flange, membrane clamp with weepholes, 12-1/2"(318) diameter fixed top, loose set heel proof ductile iron grate supported by bucket, and no hub connection (standard).

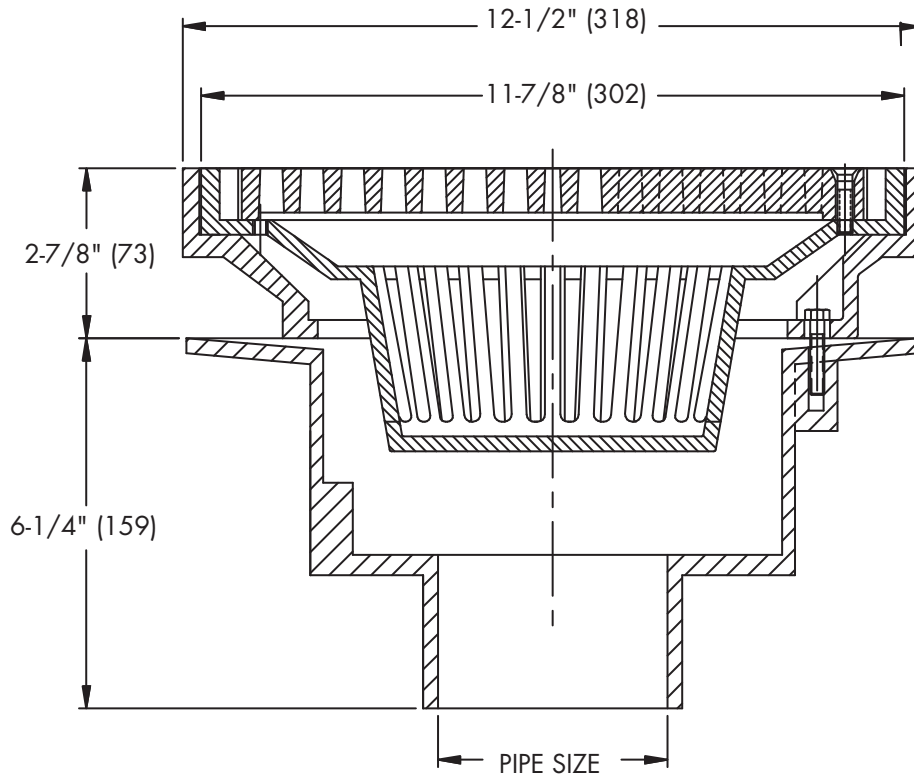

Pipe Sizing (Select One)		
Suffix	Description	
2	2"(51) Pipe Size	<input type="checkbox"/>
3	3"(76) Pipe Size	<input type="checkbox"/>
4	4"(102) Pipe Size	<input type="checkbox"/>
5	5"(127) Pipe Size (NH only)	<input type="checkbox"/>
6	6"(152) Pipe Size	<input type="checkbox"/>
8	8"(203) Pipe Size (NH only)	<input type="checkbox"/>

Outlet Type (Select One)		
Suffix	Description	
NH	No Hub (M)	<input type="checkbox"/>
P	Push On	<input type="checkbox"/>
T	Threaded Outlet	<input type="checkbox"/>
X	Inside Caulk	<input type="checkbox"/>

Options (Select One or More)		
Suffix	Description	
-1	Nickel Bronze Top	<input type="checkbox"/>
-6	Vandal Proof	<input type="checkbox"/>
-7	Trap Primer Tapping	<input type="checkbox"/>
-8	Backwater Valve (3"/4" Only)	<input type="checkbox"/>
-13	Galvanized	<input type="checkbox"/>
-34	Closure Plug	<input type="checkbox"/>
-F4-50	4" Round Cast Iron Funnel	<input type="checkbox"/>
-F4-1	4" Round Nickel Bronze Funnel	<input type="checkbox"/>
-F6-1	6" Round Nickel Bronze Funnel	<input type="checkbox"/>
-G-50	4x9" Oval Cast Iron Funnel	<input type="checkbox"/>
-G-1	4x9" Oval Nickel Bronze Funnel	<input type="checkbox"/>
-SO	Side Outlet (2,3,4 only)	<input type="checkbox"/>
-US	Buy American Compliant	<input type="checkbox"/>

Optional Body Material		
Suffix	Description	
-60	PVC Body w/Socket Outlet	<input type="checkbox"/>
-61	ABS Body w/Socket Outlet	<input type="checkbox"/>

**Load Rating & Free Area**

Load Rating	Free Area Sq. In.
*HD	16

\* The load classifications are in accordance with the American National Standards ASME A112.21.1M ASME Ratings are as follows:  
 HD - Safe Live Load 7500-10000 lbs.(3375-4500kg)  
 The above categories are given as a guide only.  
 Please consult factory.

Job Name \_\_\_\_\_ Contractor \_\_\_\_\_

Job Location \_\_\_\_\_ Contractor's P.O. No. \_\_\_\_\_

Engineer \_\_\_\_\_ Representative \_\_\_\_\_

WATTS Drainage reserves the right to modify or change product design or construction without prior notice and without incurring any obligation to make similar changes and modifications to products previously or subsequently sold. See your WATTS Drainage representative for any clarification. Dimensions are subject to manufacturing tolerances.



Specification Drainage Products

USA: 100 Watts Road, Spindale, NC, 28160-2298; TEL: 828-288-2179 TOLL-FREE: 1-800-338-2581 www.watts.com