

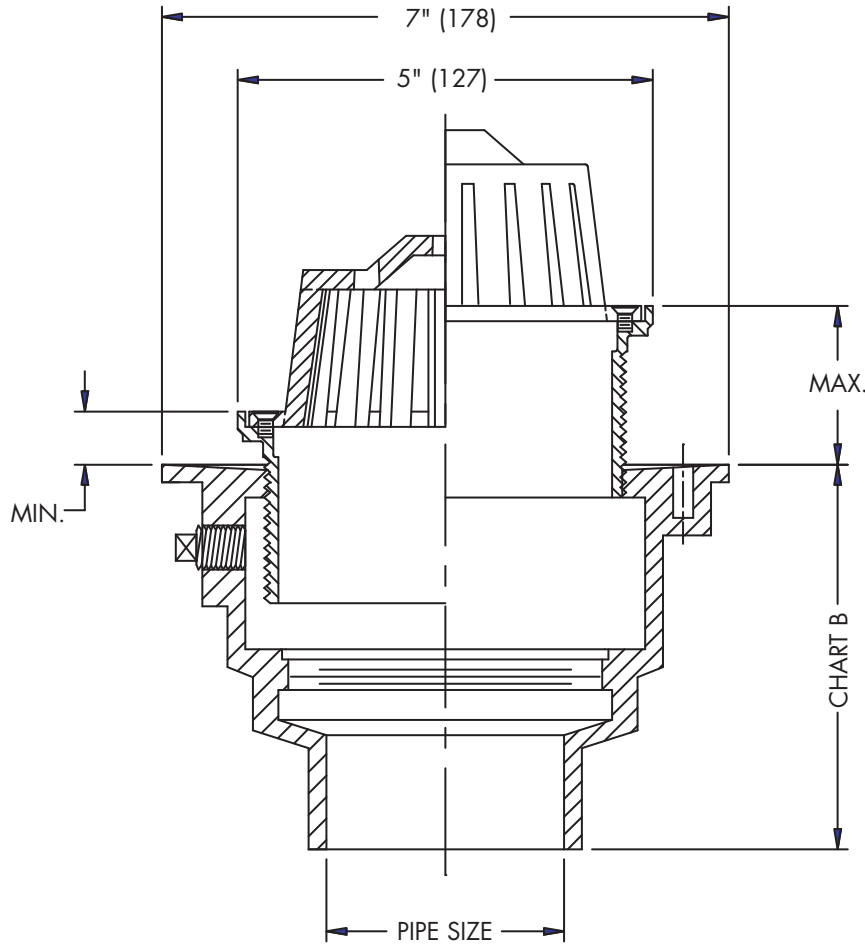

FD-200-K
Tag: _____

Floor Drain with Dome Strainer

SPECIFICATION: Watts Drainage Products FD-200-K on grade epoxy coated cast iron floor drain with anchor flange, weepholes, adjustable nickel bronze dome strainer, and no hub (standard) outlet.



Components	
B4-34	K

Pipe Sizing (Select One)		
Suffix	Description	
2	2"(51) Pipe Size	<input type="checkbox"/>
3	3"(76) Pipe Size	<input type="checkbox"/>
4	4"(102) Pipe Size	<input type="checkbox"/>

Outlet Type (Select One)		
Suffix	Description	
NH	No Hub (MJ)	<input type="checkbox"/>
P	Push On	<input type="checkbox"/>

Options (Select One or More)		
Suffix	Description	
-5	Sediment Bucket	<input type="checkbox"/>
-6	Vandal Proof	<input type="checkbox"/>
-7	Trap Primer Tapping	<input type="checkbox"/>
-8	Backwater Valve	<input type="checkbox"/>
-13	Galvanized Body	<input type="checkbox"/>
-15	Strainer Extension (DD-50)	<input type="checkbox"/>
-US	Buy American Compliant	<input type="checkbox"/>

Optional Body Material		
Suffix	Description	
-60	PVC Body w/Socket Outlet	<input type="checkbox"/>
-61	ABS Body w/Socket Outlet	<input type="checkbox"/>

Strainer Size

Str. Dia.	Min.	Max.	Load Rating	Free Area Sq. In.
5"(127)	1"(25)	2-1/4"(57)	N/A	15

Chart B

	NH(MJ)	P	60/61
Pipe Size	No Hub	Push On	PVC/ABS
2"	4-1/2" (114)	5-1/2" (140)	4" (102)
3"	4-1/2" (114)	5-1/2" (140)	4" (102)
4"	4-3/4" (121)	5-1/2" (140)	4" (102)

Job Name _____ Contractor _____

Job Location _____ Contractor's P.O. No. _____

Engineer _____ Representative _____

WATTS Drainage reserves the right to modify or change product design or construction without prior notice and without incurring any obligation to make similar changes and modifications to products previously or subsequently sold. See your WATTS Drainage representative for any clarification. Dimensions are subject to manufacturing tolerances.



Specification Drainage Products

USA: 100 Watts Road, Spindale, NC, 28160-2298; TEL: 828-288-2179 TOLL-FREE: 1-800-338-2581 www.watts.com