



FD-1160

Tag: _____

Chemical Resistant Floor Drain

SPECIFICATION: Watts Drainage FD-1160 chemical resistant PVC floor drain with anchor flange, reversible clamping collar with primary and secondary weepholes, 6-1/2"(165) round heel proof adjustable PVC strainer secured with stainless steel screws, and socket outlet.

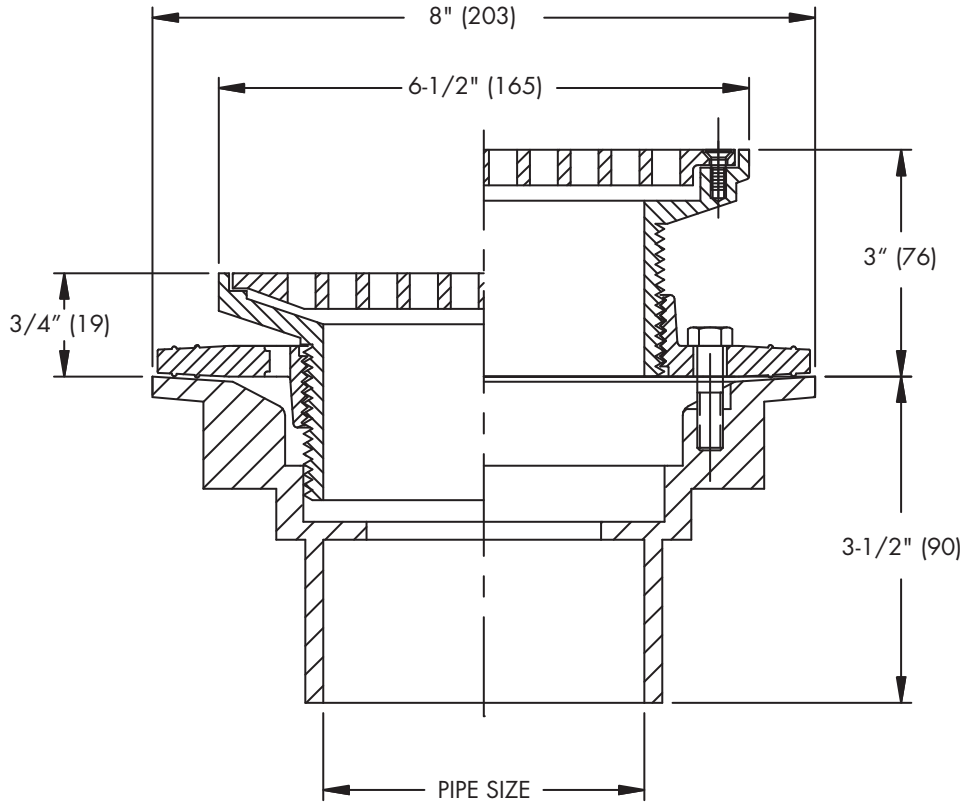

Pipe Sizing (Select One)		
Suffix	Description	
2	2"(51) Pipe Size	<input type="checkbox"/>
3	3"(76) Pipe Size	<input type="checkbox"/>
4	4"(102) Pipe Size	<input type="checkbox"/>

Options (Select One or More)		
Suffix	Description	
-5	Sediment Bucket	<input type="checkbox"/>
-6	Vandal Proof	<input type="checkbox"/>
-7	Trap Primer Tapping	<input type="checkbox"/>
-F4-1	4" Round Nickel Bronze Funnel	<input type="checkbox"/>
-F6-1	6" Round Nickel Bronze Funnel	<input type="checkbox"/>
-G-1	4x9" Oval Nickel Bronze Funnel	<input type="checkbox"/>

Load Rating & Free Area

Load Rating	Free Area Sq. In.
*LD	9

* The load classifications are in accordance with the American National Standards ASME A112.21.1M
 ASME Ratings are as follows:
 LD - Safe Live Load Under 2000 lbs.(900kg)
 The above categories are given as a guide only.
 Please consult factory.

Job Name _____ Contractor _____

Job Location _____ Contractor's P.O. No. _____

Engineer _____ Representative _____

WATTS Drainage reserves the right to modify or change product design or construction without prior notice and without incurring any obligation to make similar changes and modifications to products previously or subsequently sold. See your WATTS Drainage representative for any clarification. Dimensions are subject to manufacturing tolerances.



Specification Drainage Products

USA: 100 Watts Road, Spindale, NC, 28160-2298; TEL: 828-288-2179 TOLL-FREE: 1-800-338-2581 www.watts.com