

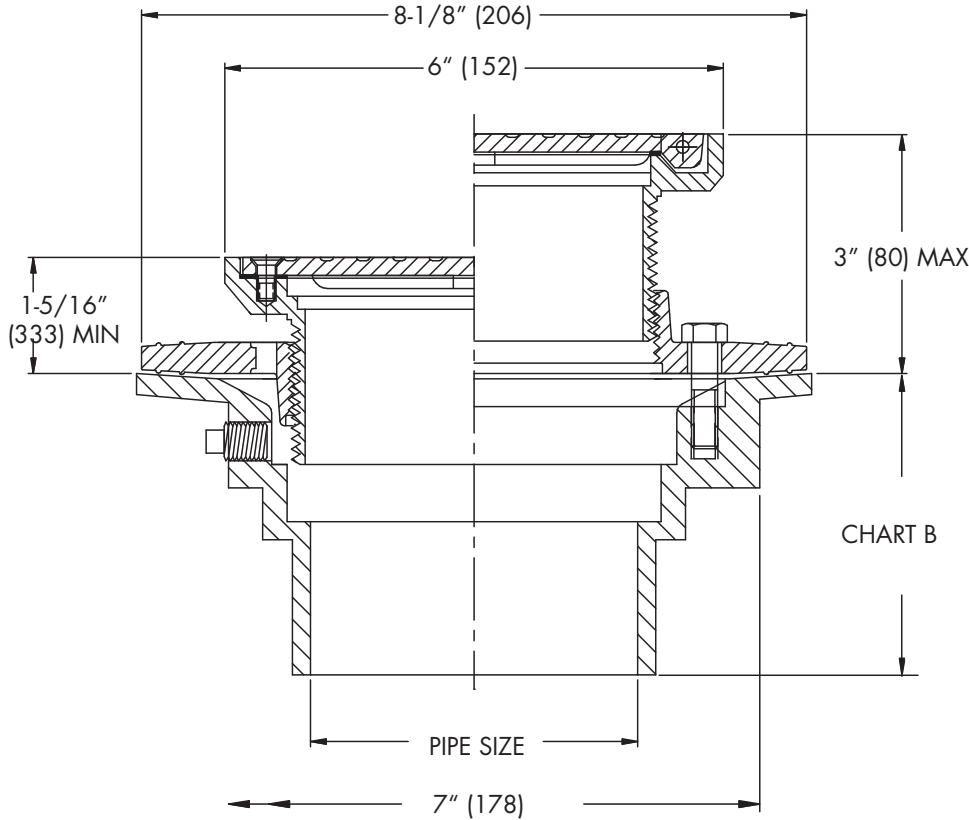

**FD-100-VS**  
Tag: \_\_\_\_\_

**Floor Drain with  
Square Hinged Solid Cover**

**SPECIFICATION:** Watts Drainage FD-100-VS epoxy coated cast iron floor drain with anchor flange, reversible clamping collar with primary & secondary weepholes, adjustable square solid hinged cover, and no hub (standard) outlet.



**Load Rating**

Suffix	Load Rating	Free Area Sq. In.
VS	*HD	NOT APPLICABLE

\* The load classifications are in accordance with the American National Standards ASME A12.21.1M ASME Ratings are as follows:  
XHD - Safe Live Load 7500-10000 lbs.(3375-4500kg)  
The above categories are given as a guide only. Please consult factory.

**Chart B**

	Std.	P	T	X	60/61
Pipe Size	No Hub	Push On	Female Thread	Inside Caulk	PVC/ABS
2"(51)	3-5/8"(92)	4-1/4"(108)	4-1/4"(108)	4-1/2"(114)	4"(102)
3"(76)	3-5/8"(92)	4-1/4"(108)	4-1/4"(108)	4-1/2"(114)	4"(102)
4"(102)	3-5/8"(92)	4-1/4"(108)	4-1/4"(108)	4-1/2"(114)	4"(102)
6"(152)	3-1/2"(89)				

**Components**

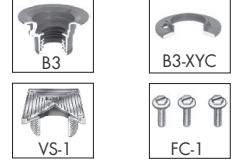

**Pipe Sizing (Select One)**

Suffix	Description	
2	2"(51) Pipe Size	<input type="checkbox"/>
3	3"(76) Pipe Size	<input type="checkbox"/>
4	4"(102) Pipe Size	<input type="checkbox"/>
6	6"(152) No Hub Only	<input type="checkbox"/>

**Outlet Type (Select One)**

Suffix	Description	
NH	No Hub (MJ)	<input type="checkbox"/>
P	Push On	<input type="checkbox"/>
T	Threaded Outlet	<input type="checkbox"/>
X	Inside Caulk	<input type="checkbox"/>

**Options (Select One or More)**

Suffix	Description	
-5	Sediment Bucket	<input type="checkbox"/>
-6	Vandal Proof	<input type="checkbox"/>
-7	Trap Primer Tapping	<input type="checkbox"/>
-8	Backwater Valve (2", 3", 4" Only)	<input type="checkbox"/>
-13	Galvanized Body	<input type="checkbox"/>
-15	Strainer Extension (DD-50)	<input type="checkbox"/>
-SO	Side Outlet	<input type="checkbox"/>
-US	Buy American Compliant	<input type="checkbox"/>

**Optional Body Material**

Suffix	Description	
-60	PVC Body w/Socket Outlet	<input type="checkbox"/>
-61	ABS Body w/Socket Outlet	<input type="checkbox"/>

Job Name \_\_\_\_\_ Contractor \_\_\_\_\_

Job Location \_\_\_\_\_ Contractor's P.O. No. \_\_\_\_\_

Engineer \_\_\_\_\_ Representative \_\_\_\_\_

WATTS Drainage reserves the right to modify or change product design or construction without prior notice and without incurring any obligation to make similar changes and modifications to products previously or subsequently sold. See your WATTS Drainage representative for any clarification. Dimensions are subject to manufacturing tolerances.



**Specification Drainage Products**

USA: 100 Watts Road, Spindale, NC, 28160-2298; TEL: 828-288-2179 TOLL-FREE: 1-800-338-2581 www.watts.com