



# FD-100-AS

Tag: \_\_\_\_\_

## Floor Drain with Angle Strainer

**SPECIFICATION:** Watts Drainage FD-100-AS epoxy coated cast iron floor drain with anchor flange, reversible clamping collar with primary & secondary weepholes, adjustable nickel bronze angle strainer, and no hub (standard) outlet.

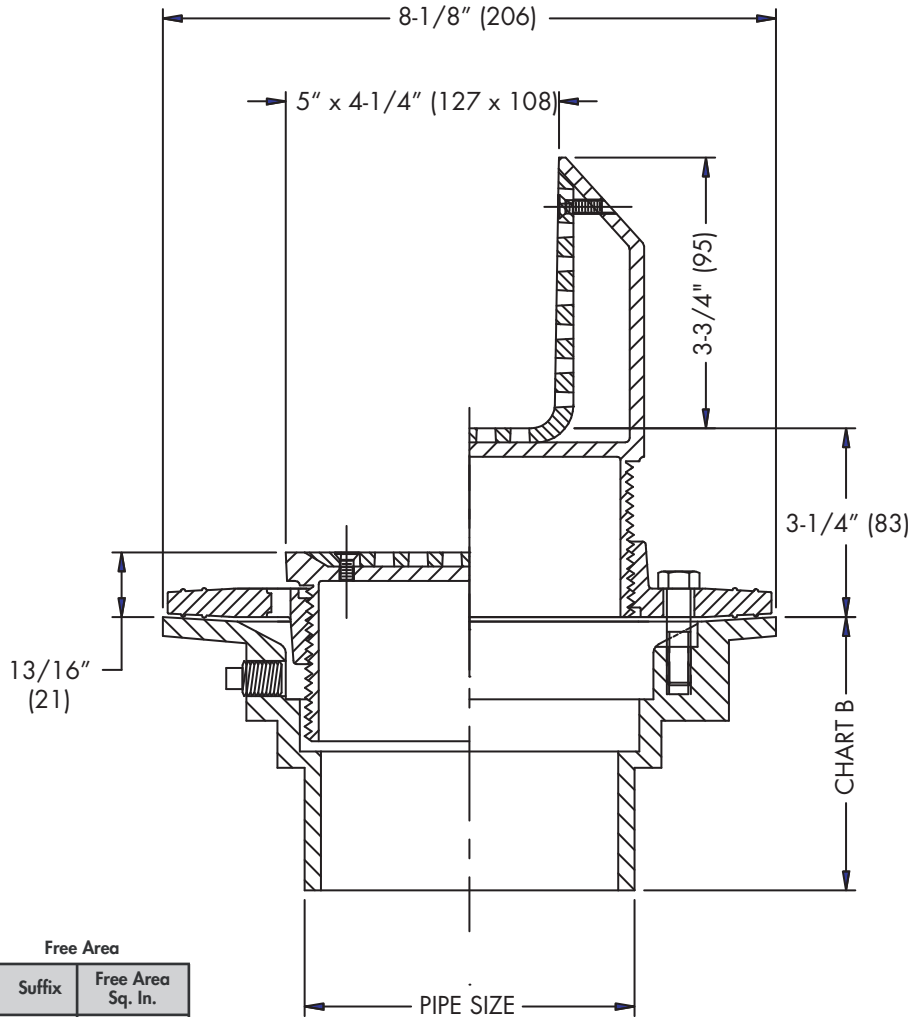

Free Area	
Suffix	Free Area Sq. In.
AS	11

Chart B

	Std.	P	T	X	60/61
Pipe Size	No Hub	Push On	Female Thread	Inside Caulk	PVC/ABS
2"(51)	3-5/8"(92)	4-1/4"(108)	4-1/4"(108)	4-1/2"(114)	4"(102)
3"(76)	3-5/8"(92)	4-1/4"(108)	4-1/4"(108)	4-1/2"(114)	4"(102)
4"(102)	3-5/8"(92)	4-1/4"(108)	4-1/4"(108)	4-1/2"(114)	4"(102)
6"(152)	3-1/2"(89)				

Components		
B3	B3-XYC	
AS	FC-1	
Pipe Sizing (Select One)		
Suffix	Description	
2	2"(51) Pipe Size	<input type="checkbox"/>
3	3"(76) Pipe Size	<input type="checkbox"/>
4	4"(102) Pipe Size	<input type="checkbox"/>
6	6"(152) No Hub Only	<input type="checkbox"/>
Outlet Type (Select One)		
Suffix	Description	
NH	No Hub (MJ)	<input type="checkbox"/>
P	Push On	<input type="checkbox"/>
T	Threaded Outlet	<input type="checkbox"/>
X	Inside Caulk	<input type="checkbox"/>
Options (Select One or More)		
Suffix	Description	
-5	Sediment Bucket	<input type="checkbox"/>
-6	Vandal Proof	<input type="checkbox"/>
-7	Trap Primer Tapping	<input type="checkbox"/>
-8	Backwater Valve (2", 3", 4" Only)	<input type="checkbox"/>
-13	Galvanized Body	<input type="checkbox"/>
-15	Strainer Extension (DD-50)	<input type="checkbox"/>
-SO	Side Outlet	<input type="checkbox"/>
-US	Buy American Compliant	<input type="checkbox"/>
Optional Body Material		
Suffix	Description	
-60	PVC Body w/Socket Outlet	<input type="checkbox"/>
-61	ABS Body w/Socket Outlet	<input type="checkbox"/>

Job Name \_\_\_\_\_ Contractor \_\_\_\_\_

Job Location \_\_\_\_\_ Contractor's P.O. No. \_\_\_\_\_

Engineer \_\_\_\_\_ Representative \_\_\_\_\_

WATTS Drainage reserves the right to modify or change product design or construction without prior notice and without incurring any obligation to make similar changes and modifications to products previously or subsequently sold. See your WATTS Drainage representative for any clarification. Dimensions are subject to manufacturing tolerances.



Specification Drainage Products

USA: 100 Watts Road, Spindale, NC, 28160-2298; TEL: 828-288-2179 TOLL-FREE: 1-800-338-2581 www.watts.com