



CO-200-TS

Tag: _____

Floor Cleanout with Square Top, Tile Recess

Components:



SPECIFICATION: Watts Drainage Products CO-200-TS epoxy coated cast iron floor cleanout with 5-1/8"(130) square adjustable nickel bronze standard top with tile recess and no hub (M) connection.

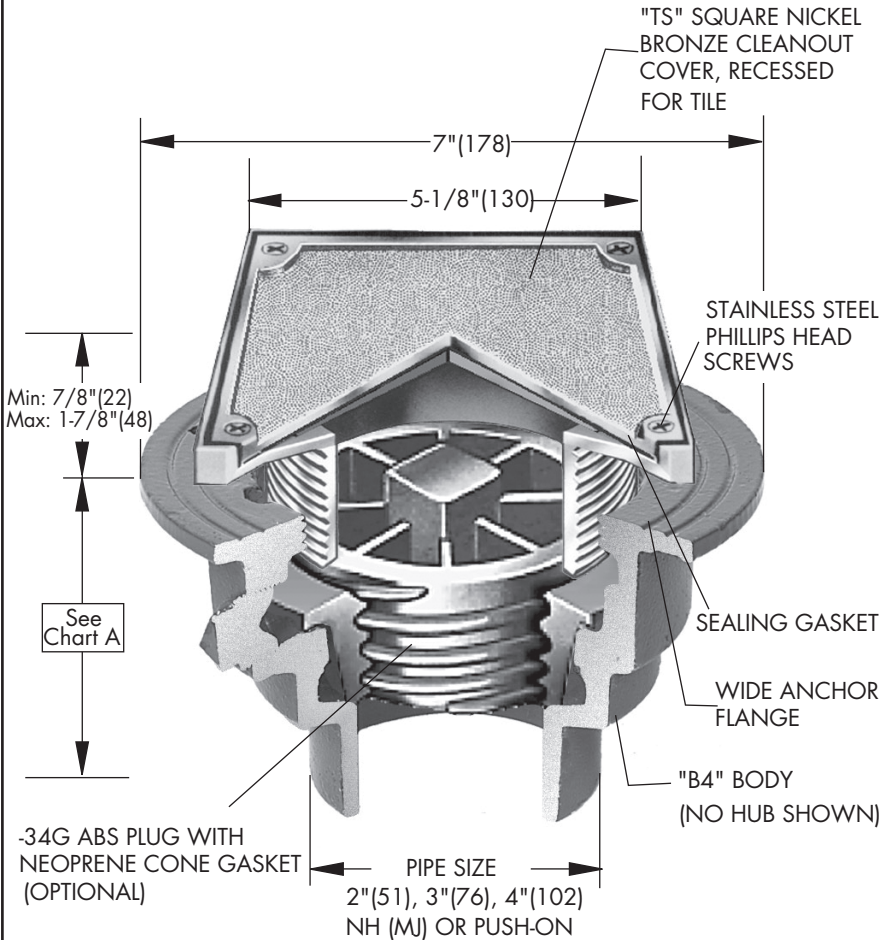

Order Code: CO-20 [] [] -TS-1- [] []

Ex. CO-202P-TS-1-6

Pipe Sizing (Select One)		
Suffix	Description	
2	2"(51) Pipe Size	<input type="checkbox"/>
3	3"(76) Pipe Size	<input type="checkbox"/>
4	4"(102) Pipe Size	<input type="checkbox"/>

Outlet Type (Select One)		
Suffix	Description	
NH	No Hub (M)	<input type="checkbox"/>
P	Push On	<input type="checkbox"/>

Options (Select One or More)		
Suffix	Description	
-6	Vandal Proof	<input type="checkbox"/>
-13	Galvanized Body	<input type="checkbox"/>
-15	Strainer Extension (DD-50)	<input type="checkbox"/>
-34G	ABS plug with Neoprene gasket	<input type="checkbox"/>
-113M	Special Epoxy from 3M Range	<input type="checkbox"/>
-C	Membrane Clamp	<input type="checkbox"/>
-Z	Elastomeric Flange	<input type="checkbox"/>

Optional Body Material (NH Only)		
Suffix	Description	
-60	PVC Body w/Socket Outlet	<input type="checkbox"/>
-61	ABS Body w/Socket Outlet	<input type="checkbox"/>

Chart A

	Std.	P	60/61
Pipe Size	No Hub	Push On	PVC/ABS
2"(51)	3"(76)	4"(102)	4"(102)
3"(76)	3"(76)	4"(102)	3-3/4"(95)
4"(102)	3"(76)	4"(102)	3-3/4"(95)

Load Rating

Suffix	Load Rating
TS-1	*MD

NOTICE

The load classifications are in accordance with the American National Standards ASME A112.21.1M ASME Ratings are as follows:
 MD - Safe Live Load 2000-4999 lbs.(900-2250kg)
 The above categories are given as a guide only.
 Please consult factory.

Job Name _____

Contractor _____

Job Location _____

Contractor's P.O. No. _____

Engineer _____

Representative _____

Watts product specifications in U.S. customary units and metric are approximate and are provided for reference only. For precise measurements, please contact Watts Technical Service. Watts reserves the right to change or modify product design, construction, specifications, or materials without prior notice and without incurring any obligation to make such changes and modifications on Watts products previously or subsequently sold.

USA: Tel: (800) 338-2581 • Fax: (828) 248-3929 • Watts.com
Canada: Tel: (905) 332-4090 • Fax: (905) 332-7068 • Watts.ca
Latin America: Tel: (52) 81-1001-8600 • Fax: (52) 81-8000-7091 • Watts.com



A Watts Water Technologies Company