



CO-100-C-U

Tag: _____

Floor Cleanout with Round Top, Terrazzo Recess

Components:



SPECIFICATION: Watts Drainage Products CO-100-C-U epoxy coated cast iron clean out with anchor flange, reversible membrane clamp, and adjustable combined access cover and plug with gasket seal.

"U" NICKEL BRONZE (STANDARD) COMBINED COVER & PLUG

Order Code: CO-10 -C-U-1-

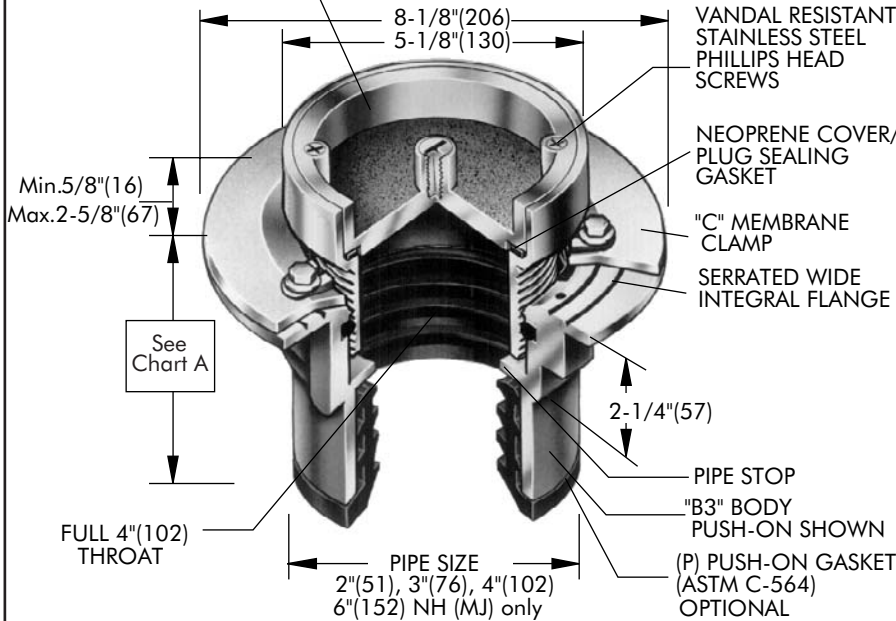

Ex. CO-102P-C-U-1-6

Pipe Sizing (Select One)	
Suffix	Description
2	2"(51) Pipe Size <input type="checkbox"/>
3	3"(76) Pipe Size <input type="checkbox"/>
4	4"(102) Pipe Size <input type="checkbox"/>
6	6"(152) Pipe Size <input type="checkbox"/>

Outlet Type (Select One)	
Suffix	Description
NH	No Hub (MJ) <input type="checkbox"/>
P	Push On <input type="checkbox"/>
T	Threaded Outlet <input type="checkbox"/>
X	Inside Caulk <input type="checkbox"/>

Options (Select One or More)	
Suffix	Description
-6	Vandal Proof <input type="checkbox"/>
-13	Galvanized Body <input type="checkbox"/>
-15	Strainer Extension (DD-50) <input type="checkbox"/>
-34B	Brass Tapered Threaded Plug <input type="checkbox"/>
-34G	Gas Tight ABS Expansion Plug <input type="checkbox"/>
-113M	Special Epoxy from 3M Range <input type="checkbox"/>
-SO	Side Outlet <input type="checkbox"/>
-Z	Elastomeric Flange <input type="checkbox"/>

Optional Body Material (NH Only)	
Suffix	Description
-60	PVC Body w/Socket Outlet <input type="checkbox"/>
-61	ABS Body w/Socket Outlet <input type="checkbox"/>

Chart A

	Std.	P	T	X	60/61
Pipe Size	No Hub	Push On	Female Thread	Inside Caulk	PVC/ABS
2"(51)	3-5/8"(92)	4-1/4"(108)	4-1/4"(108)	4-1/2"(114)	3-3/4"(95)
3"(76)	3-5/8"(92)	4-1/4"(108)	4-1/4"(108)	4-1/2"(114)	3-3/4"(95)
4"(102)	3-5/8"(92)	4-1/4"(108)	4-1/4"(108)	4-1/2"(114)	4"(102)
6"(152)	3-1/2"(89)				

Load Rating

Suffix	Load Rating
U-1	*MD

* The load classifications are in accordance with the American National Standards ASME A112.21.1M ASME Ratings are as follows:
MD - Safe Live Load 2000-4999 lbs.(900-2250kg)
These categories are given as a guide only. Please consult factory.

Job Name _____ Contractor _____

Job Location _____ Contractor's P.O. No. _____

Engineer _____ Representative _____

Watts Drainage reserves the right to modify or change product design or construction without prior notice and without incurring any obligation to make similar changes and modifications to products previously or subsequently sold. See your Watts Drainage representative for any clarification. Dimensions are subject to manufacturing tolerances.



CANADA: 5435 North Service Road, Burlington, ON, L7L 5H7 TEL: 905-332-6718 TOLL-FREE: 1-888-208-8927 Website: www.wattsdrainage.ca

