



**CO-100-C-S**

Tag: \_\_\_\_\_

**Floor Cleanout  
with Square Top**

**Components:**

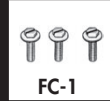

**SPECIFICATION:** Watts Drainage Products CO-100-C-S epoxy coated cast iron cleanout with anchor flange, reversible membrane clamp, and adjustable combined access cover and plug with gasket seal.

"S" NICKEL BRONZE  
(STANDARD) COMBINED  
COVER & PLUG

Order Code: **CO-10**   - **C** -  -  -  -

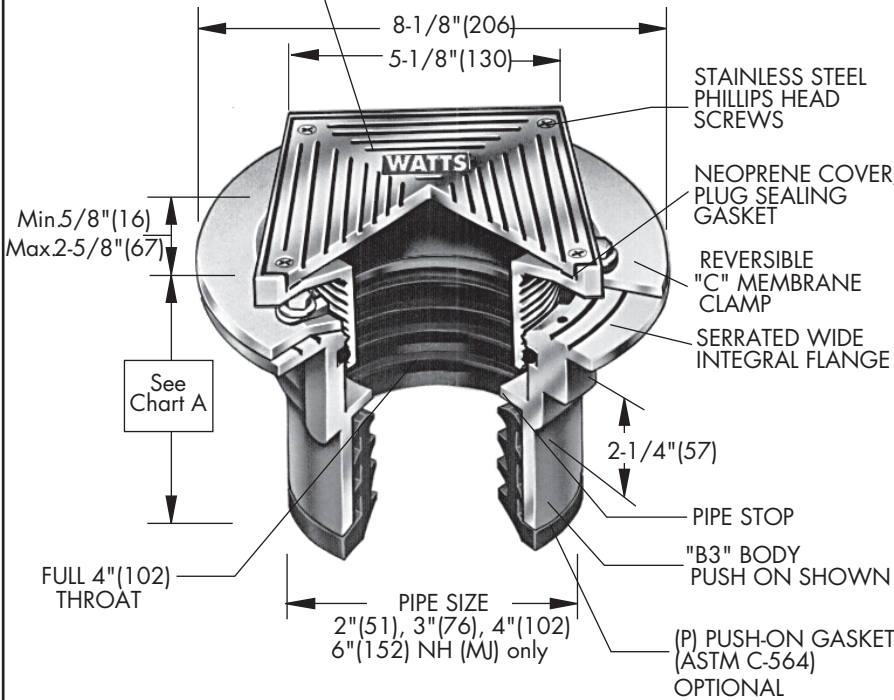

**Ex. CO-102P-C-S-1-6**

Pipe Sizing (Select One)	
Suffix	Description
2	2"(51) Pipe Size <input type="checkbox"/>
3	3"(76) Pipe Size <input type="checkbox"/>
4	4"(102) Pipe Size <input type="checkbox"/>
6	6"(152) Pipe Size <input type="checkbox"/>

Outlet Type (Select One)	
Suffix	Description
NH	No Hub (MJ) <input type="checkbox"/>
P	Push On <input type="checkbox"/>
T	Threaded Outlet <input type="checkbox"/>
X	Inside Caulk <input type="checkbox"/>

Cover	
Suffix	Description
S-1	5"(127) Sqr., Nickel Bronze <input type="checkbox"/>
S-3	5"(127) Sqr., Stainless Steel <input type="checkbox"/>

Options (Select One or More)	
Suffix	Description
-6	Vandal Proof <input type="checkbox"/>
-13	Galvanized Body <input type="checkbox"/>
-15	Strainer Extension (DD-50) <input type="checkbox"/>
-34B	Brass Tapered Threaded Plug <input type="checkbox"/>
-34G	Gas Tight ABS Expansion Plug <input type="checkbox"/>
-113M	Special Epoxy from 3M Range <input type="checkbox"/>
-SO	Side Outlet <input type="checkbox"/>
-Z	Elastomeric Flange <input type="checkbox"/>

Optional Body Material (NH Only)	
Suffix	Description
-60	PVC Body w/Socket Outlet <input type="checkbox"/>
-61	ABS Body w/Socket Outlet <input type="checkbox"/>

Chart A

	Std.	P	T	X	60/61
Pipe Size	No Hub	Push On	Female Thread	Inside Caulk	PVC/ABS
2"(51)	3-5/8"(92)	4-1/4"(108)	4-1/4"(108)	4-1/2"(114)	3-3/4"(95)
3"(76)	3-5/8"(92)	4-1/4"(108)	4-1/4"(108)	4-1/2"(114)	3-3/4"(95)
4"(102)	3-5/8"(92)	4-1/4"(108)	4-1/4"(108)	4-1/2"(114)	4"(102)
6"(152)	3-1/2"(89)				

**Load Rating**

Suffix	Load Rating
S-1	*MD
S-3	*MD

\* The load classifications are in accordance with the American National Standards ASME A112.21.1M ASME Ratings are as follows:  
MD - Safe Live Load 2000-4999 lbs. (900-2250 kg)  
These categories are given as a guide only.  
Please consult factory.

Job Name \_\_\_\_\_

Contractor \_\_\_\_\_

Job Location \_\_\_\_\_

Contractor's P.O. No. \_\_\_\_\_

Engineer \_\_\_\_\_

Representative \_\_\_\_\_

Watts product specifications in U.S. customary units and metric are approximate and are provided for reference only. For precise measurements, please contact Watts Technical Service. Watts reserves the right to change or modify product design, construction, specifications, or materials without prior notice and without incurring any obligation to make such changes and modifications on Watts products previously or subsequently sold.



A Watts Water Technologies Company

**USA:** Tel: (800) 338-2581 • Fax: (828) 248-3929 • Watts.com

**Canada:** Tel: (905) 332-4090 • Fax: (905) 332-7068 • Watts.ca

**Latin America:** Tel: (52) 81-1001-8600 • Fax: (52) 81-8000-7091 • Watts.com

ES-WD-CO-100-C-S-CAN 1444

© 2014 Watts