



# CA-421-HFH

Tag: \_\_\_\_\_

## Floor Supported Carrier for Barrier-free Heavy Duty Hanger

**SPECIFICATION:** Watts Drainage Products CA-421-HFH carrier with heavy duty foot support, heavy duty rectangular steel structural uprights and heavy duty fixture hanger supporting plate.

**FUNCTION:** Recommended for support of barrier-free basin with heavy duty fixture hanger independent of wall.

**Carrier manufactured for installation with:**

American-standard Elise Petite - AF-0030 /35 \* Liberty Crane Diana - 1-26

Order Code: **CA-421-HFH-**

Ex. **CA-421-HFH-M51**

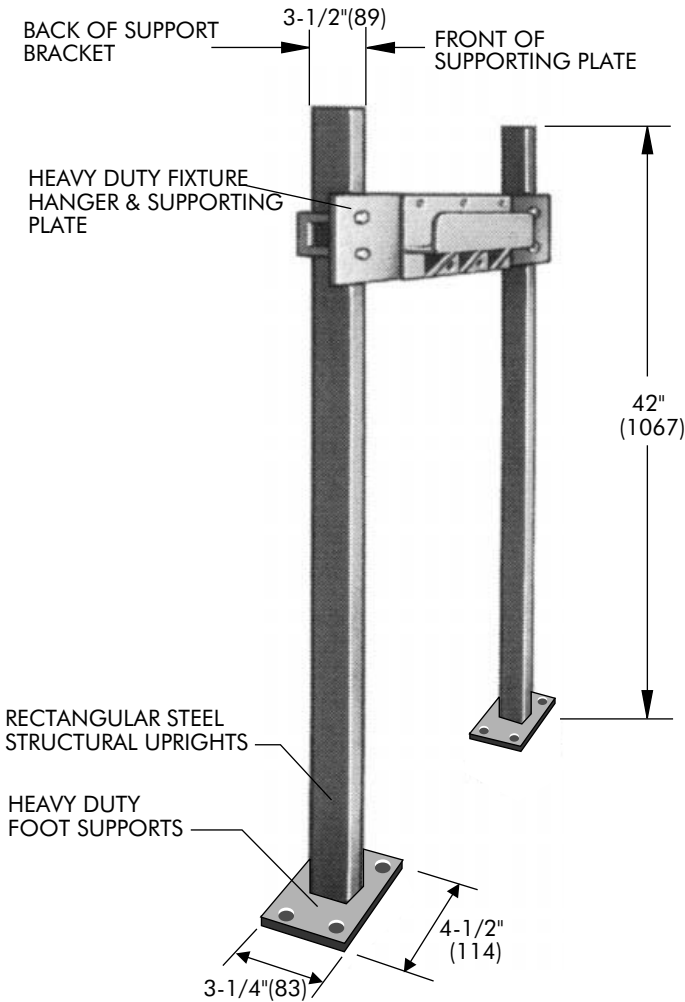

Options (Select One or More)		
Suffix	Description	
-M51	Wall Thickness over 5", per add inch (single)	<input type="checkbox"/>
-M52	Wall Thickness over 12", per inch (Back to Back)	<input type="checkbox"/>
-M53	Vandal Proof Trim, Single	<input type="checkbox"/>
-M59	Floor to Ceiling Adaptor, Single	<input type="checkbox"/>
-M60	Valve Supporting Plate, Single	<input type="checkbox"/>
-M61	Valve Supporting Bar, Single	<input type="checkbox"/>
-M62	Flush Valve Piping Support, Single	<input type="checkbox"/>

Job Name \_\_\_\_\_ Contractor \_\_\_\_\_

Job Location \_\_\_\_\_ Contractor's P.O. No. \_\_\_\_\_

Engineer \_\_\_\_\_ Representative \_\_\_\_\_

WATTS Drainage reserves the right to modify or change product design or construction without prior notice and without incurring any obligation to make similar changes and modifications to products previously or subsequently sold. See your WATTS Drainage representative for any clarification. Dimensions are subject to manufacturing tolerances.



CANADA: 5435 North Service Road, Burlington, ON, L7L 5H7 TEL: 905-332-6718 TOLL-FREE: 1-888-208-8927 Website: www.wattsdrainage.ca

