

Product Specification

Features ■

- Paraffin-based advanced thermal actuation technology to sense and adjust outlet temperature
- Dirt and lime resistant poppet and seat design
- Virtual shutoff if supply pressure fails
- Vandal-resistant locking mechanism to secure temperature setting
- Factory tested as a complete unit
- Mounted on heavy-duty welded struts
- Stainless steel or white painted cabinets
- Pressure/Temperature Gauges, Ball valves

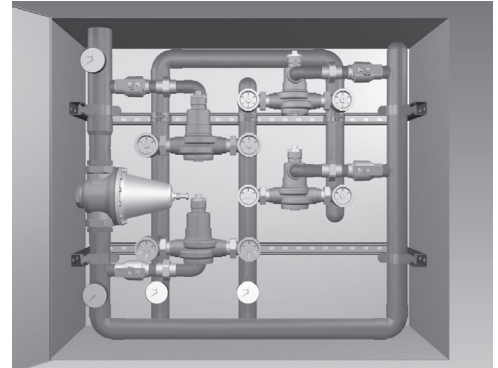

Specifications ■

- Connections See ordering information
- Maximum Hot Water Supply Temperature 200°F (93°C)
- Minimum Hot Water Supply Temperature* . . . 5°F (3°C) Above Set Point
- Minimum Flow** 0.5 gpm (1.9 lpm)
- Maximum Operating Pressure 125psi (861 kPa)
- Temperature Adjustment Range*** 90 - 160°F (32 - 71°C)
- Hot Water Inlet Temperature Range 120 - 180°F (49 - 82°C)
- Cold Water Inlet Temperature Range 40 - 80°F (4 - 27°C)
- Listing/Compliance (Valve Only). ASSE 1017, CSA B125

* With Equal Pressure

** Minimum flow when Hi/Lo valve is installed at or near hot water source recirculating tempered water with a properly sized continuously operating recirculating pump.

*** Note: Low limit cannot be less than the cold water temperature. For best operation, hot water should be at least 5°F (3°C) above desired set point.

Capacity ■

Flow Capacity at 50-50 Mixed Ratio								
		Pressure Drop Across Valve						
Model	Min. Flow to ASSE 1017	Cv	5psi (34 kPa)	10psi (69 kPa)	20psi (138 kPa)	30psi (207 kPa)	45psi (310 kPa)	60psi (414 kPa)
SH1434QV	1 gpm 4 lpm	83.3	186 gpm 704 lpm	263 gpm 996 lpm	373 gpm 1412 lpm	456 gpm 1726 lpm	559 gpm 2116 lpm	645 gpm 2442 lpm

Dimensions ■

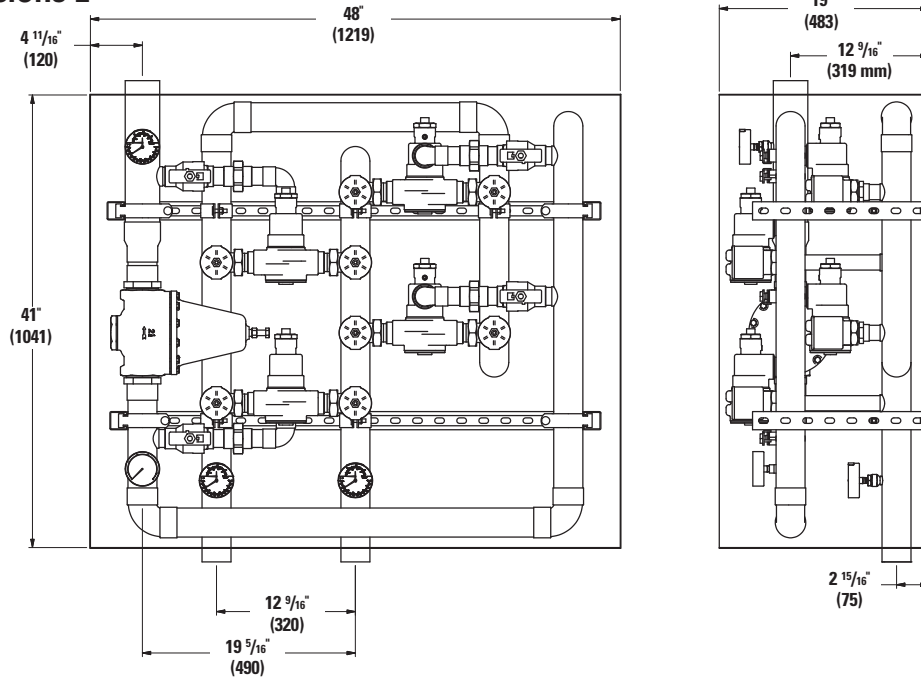

Note:
Dimensions are shown ±1/2"
Dimensions in parentheses are in mm

Ordering Information ■



Valve	Inlets	Outlet	Order Code
Quad Valve	2-1/2" (65mm)	3" (80mm)	QV
Finish			
Rough Bronze			A
Piping			
Bottom/Top			E
Cabinets			
Stainless Steel, Wall Mount			Q
Painted Steel, Wall Mount			U
Alarm			
None			0

Recirculation Piping Diagram ■

Please see Piping Diagram Section of this catalog.

Typical Specification ■

Quad Valve Hi/Lo temperature control system should include four thermostatic valves capable of maintaining water temperature to within the range of 90 – 160°F (32 – 71°C). Valves must compensate for fluctuations due to inlet water temperature changes. Valves shall be of bronze body with triple-duty checkstops and must have advanced, paraffin-based thermal actuation technology in order to guarantee a precise control when tested in accordance with ASSE 1017 and CSA B125. Thermostatic valves must be ASSE listed and CSA approved. Quad-valve Hi/Lo system must include PRV, ball valves, pressure/temperature gauges and mounted on heavy-duty metal struts. It shall also include a stainless steel or painted steel cabinet. The Hi/Lo system shall be of Powers' Quad Valve Hi/Lo Model _____. Any alternate must have a written approval prior to bidding.

ENGINEERING APPROVAL

Project: _____
Contractor: _____
Architect/Engineer: _____

POWERS™

A Watts Water Technologies Company



**ISO 9001-2000
CERTIFIED**

USA: Phone: 1.800.669.5430 • Fax 1.847.229.0526 • www.powerscontrols.com
Canada: Phone: 1.888.208.8927 • Fax 1.888.479.2887 • www.powerscontrols.ca