

**HydroGuard® XP Series Emergency
Tempering Valves Supply Fixtures
Top Inlets/Bottom Outlet Semi-Recessed Cabinet**

Product Specification

Features ■

- Powers' Advanced Thermal Actuator provides precise temperature control
- Exclusive internal cold water bypass ensures cold water flow in the event of loss of hot water
- Flow effectively shuts down upon loss of cold water supply when tested under the condition specified in ASSE 1071 standard
- Vandal-resistant locking mechanism to secure temperature setting
- Factory tested
- Rotatable union triple-duty checkstops
- Rough bronze and chrome finishes

Patent Pending



Advanced Thermal Activation

Specifications ■

- Connections See on the back
- Maximum Operating Pressure 125psi (861 kPa)
- Maximum Hot Water Temperature 180°F (82°C)
- Temperature Adjustment Range 60 – 95°F (15 – 35°C)
- Factory Set Temperature* 85°F (29°C)
- Bypass Flow Rate at 30psid*
- ETV200 30 gpm (114 lpm)
 - ETV400 51 gpm (189 lpm)
 - ETV500 81 gpm (307 lpm)
- Maximum flow with cold water shutoff* 0.5 gpm (1.9 lpm)
- Listing ASSE 1071 and IAPMO UPC

**When tested under conditions specified in ASSE 1071 Standard*

Capacity ■

Flow Capacity at 85°F (29.4°C)									
Model	Min. Flow to ASSE 1071	C _v	Pressure Drop Across Valve						
			5psi (34 kPa)	10psi (69 kPa)	15psi (103 kPa)	20psi (138 kPa)	30psi (207 kPa)	45psi (310 kPa)	60psi (414 kPa)
ETV200	3.0 gpm 11.4 lpm	6	13.4 gpm 50.7 lpm	19.0 gpm 71.9 lpm	23.2 gpm 87.8 lpm	26.8 gpm 101.4 lpm	32.9 gpm 124.5 lpm	40.2 gpm 152.2 lpm	46.5 gpm 176.0 lpm
ETV400	3.0 gpm 11.4 lpm	15.2	34.0 gpm 128.7 lpm	48.1 gpm 182.0 lpm	58.9 gpm 223.0 lpm	68.0 gpm 257.4 lpm	83.2 gpm 315.0 lpm	102.0 gpm 386.1 lpm	118.0 gpm 446.7 lpm
ETV500	3.0 gpm 11.4 lpm	21.8	48.7 gpm 184.3 lpm	68.9 gpm 260.8 lpm	84.4 gpm 319.5 lpm	97.5 gpm 369.1 lpm	119.4 gpm 452.0 lpm	146.2 gpm 553.4 lpm	168.9 gpm 639.4 lpm

Dimensions ■

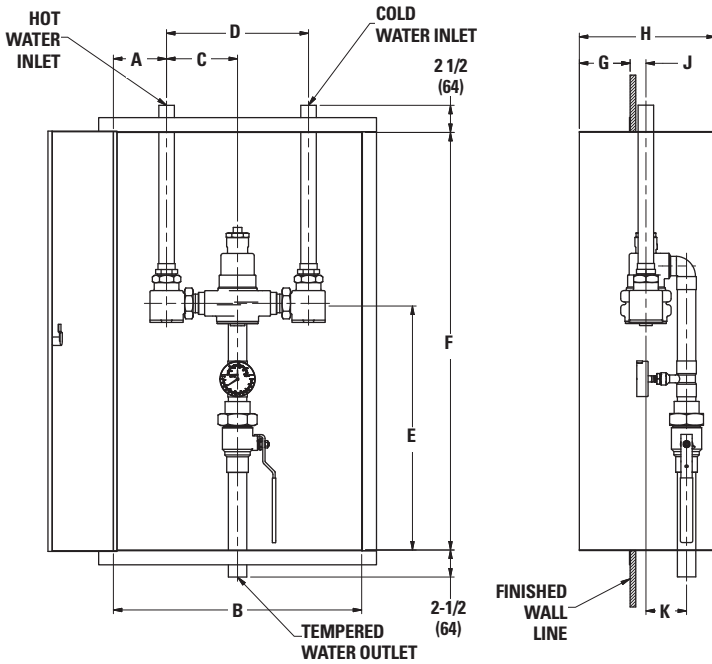

Valve	A	B	C	D	E	F	G	H	J	K
ETV200	4-7/8 (125)	19 (483)	4-5/8 (116)	9-1/8 (233)	14-1/4 (363)	30 (762)	3-1/2 (87)	9 (70)	1-1/8 (28)	2-3/4 (70)
ETV400	4-3/4 (120)	22 (559)	6-1/4 (160)	12-5/8 (320)	21-7/8 (555)	37 (940)	4-1/2 (113)	12 (305)	1-3/8 (36)	3-3/4 (95)
ETV500	5-1/8 (132)	26 (660)	7-7/8 (199)	15-5/8 (397)	24-3/8 (618)	44 (1118)	4 (100)	13 (329)	2 (52)	4-1/4 (108)

Note:

Dimensions are shown $\pm 1/2''$

Dimensions in parentheses are in mm

Valve	Inlets	Outlet
ETV200	3/4" (20)	1" (25)
ETV400	1-1/4" (32)	1-1/2" (40)
ETV500	2" (50)	2" (50)

Ordering Information ■

Valve

32.9 gpm (124.5 lpm) @ 30psi (207 kPa)
83.2 gpm (315.0 lpm) @ 30psi (207 kPa)
119.4 gpm (452.0 lpm) @ 30psi (207 kPa)

Finish

Rough Bronze
Chrome Plated

Piping Inlets/Outlet

Top/Bottom

Cabinet Style

Stainless Steel, Semi-Recessed
Painted, Semi-Recessed

Options

None
T/P Gauge on Inlets

Alarm System

None
AquaSentry2®

View Port

None
Window

Order Code

ETV200
ETV400
ETV500

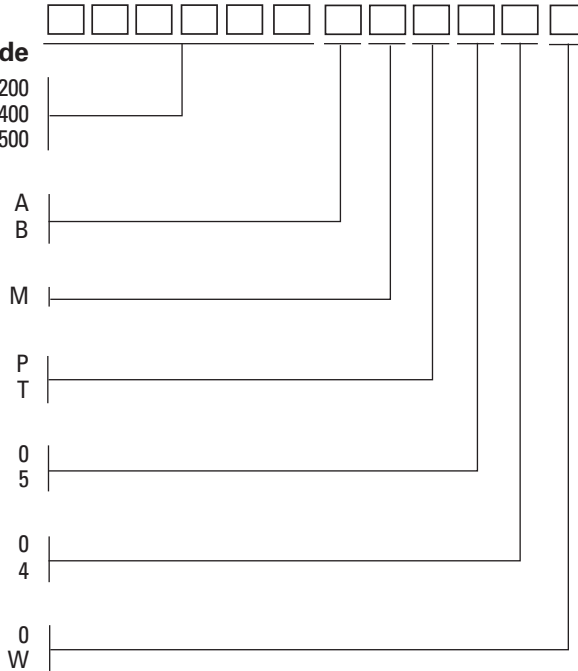

Recirculation Piping Diagram ■

Please see Piping Diagram Section of this catalog.

Typical Specification ■

Cabinet Supply Fixture for supplying tepid water to emergency fixtures shall be factory assembled, tested and include a stainless steel or painted steel cabinet. Thermostatic mixing valve must have internal cold-water bypass system to ensure flow in the event of valve failure or loss of hot water supply. Supply fixture also includes copper piping, ball valve (s) and temperature/pressure gauge for diagnostics. The valve shall be listed to ASSE 1071 and IAPMO UPC, provide precise temperature control over a wide range of flow conditions, and effectively shut down on loss of cold water. The valve shall feature paraffin-based actuation technology and checkstops to prevent cross flow. The valve shall be factory set to 85°F (29°C) with a lockable mean of securing the temperature.

The valve shall be Powers' model ETV200 _____, ETV400 _____ or ETV500 _____. All alternatives must have written approval prior to bidding.

ENGINEERING APPROVAL

Project: _____

Contractor: _____

Architect/Engineer: _____



ISO 9001-2000
CERTIFIED

POWERS™

A Watts Water Technologies Company

USA: Phone: 1.800.669.5430 • Fax 1.847.229.0526 • www.powerscontrols.com

Canada: Phone: 1.888.208.8927 • Fax 1.888.479.2887 • www.powerscontrols.ca