

SPECIFICATION SHEET **FEBCO**

MASTER series

MasterSeries® 880V

Reduced Pressure Zone Assemblies

Size: 2½" - 10" (65mm - 250mm)

The FEBCO MasterSeries® 880V Reduced Pressure Zone Assemblies are designed for use in health hazard applications. Standard orientation is inlet flow vertical up, outlet flow vertical down. Vertical orientation is inlet and outlet flow vertical up.

Pressure – Temperature

Temperature Range: 32°F to 140°F (0°C to 60°C)
 Max. Working Pressure: 175psi (12.1 bar)
 Hydrostatic Test Press: 350psi (24.1 bar)

Materials

Main Valve Body: Ductile iron Grade 65-45-12
 Coating: Fusion epoxy coated internal and external AWWA C550
 Shutoff Valves: NRS and OS&Y resilient wedge gate valves AWWA C509
 Trim: Bronze
 Elastomer Discs: EPDM
 Spring: Stainless steel

Approvals – Standards

- ANSI/AWWA (C511)
- Approved by the Foundation for Cross-Connection Control and Hydraulic Research at the University of Southern California.



MODEL 880V REDUCED PRESSURE ZONE ASSEMBLY
 (Shown in vertical orientation)

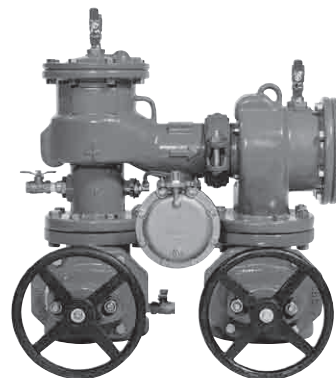

MODEL 880V REDUCED PRESSURE ASSEMBLY
 (Shown in standard orientation)

* Less gate not FM approved. Less gate not UL Classified unless installed with UL Listed gate valves.

Models

Valve Setter with MJ x MJ, MJ x FL, or FL x FL ends
 UL/FM OS&Y RW Gate Valves
 Relief Valve Air Gap Drain Funnel
 Wye Strainer
 End Connections: Flanged ANSI B16.1
 Class 125

IMPORTANT: INQUIRE WITH GOVERNING AUTHORITIES FOR LOCAL INSTALLATION REQUIREMENTS

Job Name _____
 Job Location _____
 Engineer _____
 Approval _____

Contractor _____
 Approval _____
 Contractor's P.O. No. _____
 Representative _____

FEBCO product specifications in U.S. customary units and metric are approximate and are provided for reference only. For precise measurements, please contact FEBCO. FEBCO reserves the right to change or modify product design, construction, specifications, or materials without prior notice and without incurring any obligation to make such changes and modifications on FEBCO products previously or subsequently sold.

Model 880V / Materials of Construction

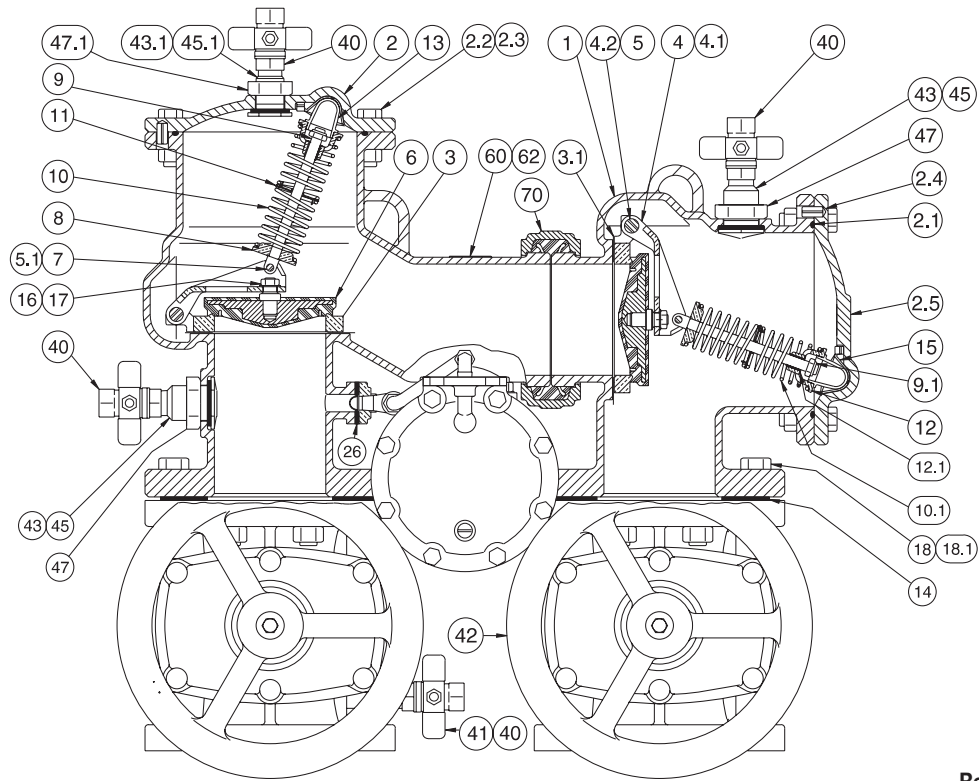

Relief Valve Detail

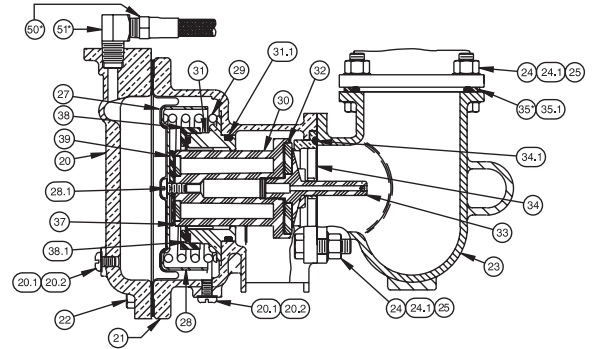

10" (250mm) Disc Assembly

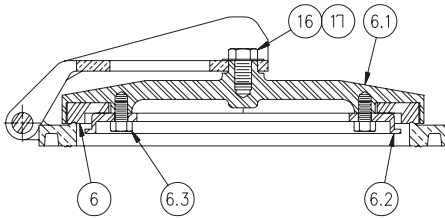

#	DESCRIPTION	MATERIAL	#	DESCRIPTION	MATERIAL	#	DESCRIPTION	MATERIAL
1	Body	A536 GR 65-45-12	14	Flange Gasket	Rubber/Fabric	36	Adaptor Plate	Alloy
2	Cover 1st Check	A536 GR 65-45-12	15	Bearing Socket	Acetal Resin	37	Sm. Diaphragm	Nitrile ASTM D2000
2.1	O-Ring	EPDM ASTM D2000	16	Hex Jam Nut	SS	38	Retainer	Alloy
2.2	Capscrew	Plated Steel	17	Washer	SS	38.1	Slip Ring	Acetal Resin
2.3	Hex Nut	Plated Steel	18	Flange Bolt	Plated Steel	39	Flow Washer	Acetal Resin
2.4	Expansion Pin	SS	18.1	Flange Nut	Plated Steel	40	Ball Valve	Alloy
2.5	Cover 2nd Check	A536 GR 65-45-12	20	R.V. Cover	Alloy	41	Nipple	Brass
3	Seat Ring	B584 Alloy C83600	20.1	Bleed Screw	SS	42	Gate Valve	AWWA C509
3.1	Gasket	EPDM ASTM D2000	20.2	Gasket	HDPE	43	Bulkhead Fitting	Alloy
4	Arm	B584 Alloy C83600	21	R.V. Body	Alloy	43.1	Bulkhead Fitting	Alloy
4.1	Bushing Swg Pin	Acetal Resin	22	Cover Bolt	SS	45	Gasket	EPDM ASTM D2000
4.2	Swing Pin	SS	23	Elbow	A536 GR 65-45-12	45.1	Gasket	EPDM ASTM D2000
5	Retaining Clip	SS	24	RV Mtg Bolt	Plated Steel	47	Nut	Alloy
5.1	Hairpin Cotter	SS	24.1	Washer - RV	Plated Steel	50	Sensing Line	SAE Hydraulic Hose
6	Check Disk	EPDM Coated GR, 45	25	RV Mtg Bolt	Plated Steel	51	Street Elbow	Alloy
6.1	Seat Disk	Ductile Iron w/ SS Stem	27	Lrg. Diaphragm	Nitrile ASTM D2000	60	Identification Plate	Alloy
6.2	Disk Retainer (10")		28	Button	A240 304 SS	62	Drive Screw	SS
6.3	Capscrew (10")		28.1	Flow Screw	Acetal Resin	70	Clamp (880V)	AWWA C606
7	Load Pin	SS	29	RV Spring	SS			
9	Spring Stem	SS	30	Stem - RV	Acetal Resin			
9.1	Elastic Stop Jam Nut	SS	31	Main Guide - RV	Alloy			
10	Spring 1st Check	SS	31.1	O-Ring - RV	FDA EPDM			
10.1	Spring 2nd Check	SS	32	Seat Disc - RV	EPDM ASTM D2000			
11	Spring Guide	SS	33	Lower Guide	Acetal Resin			
12	Upr Spring Retnr	Alloy	34	Seat Disc	Alloy			
12.1	Bushing-Spr. Stem	Acetal Resin	34.1	O-Ring	FDA EPDM			
13	Pivot Bearing	Alloy	35	O-Ring	Acetal Resin			
			35.1	Back-Up Ring	EPDM ASTM D2000			

Model 880V
Standard Orientation

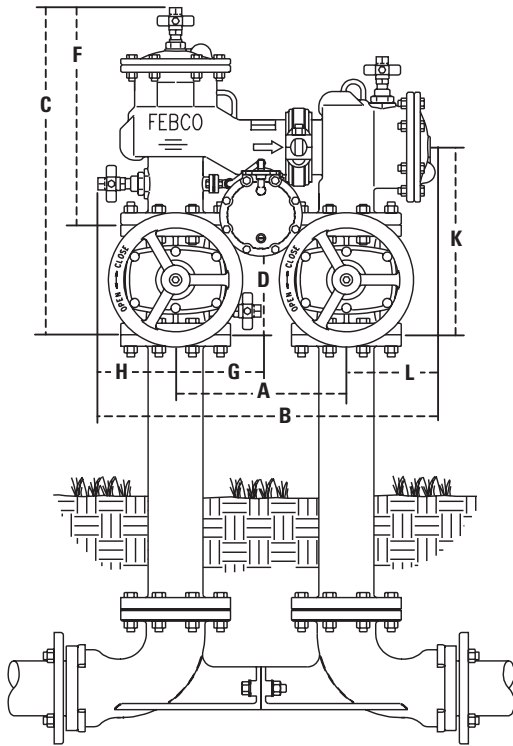

Model 880V
Vertical Orientation

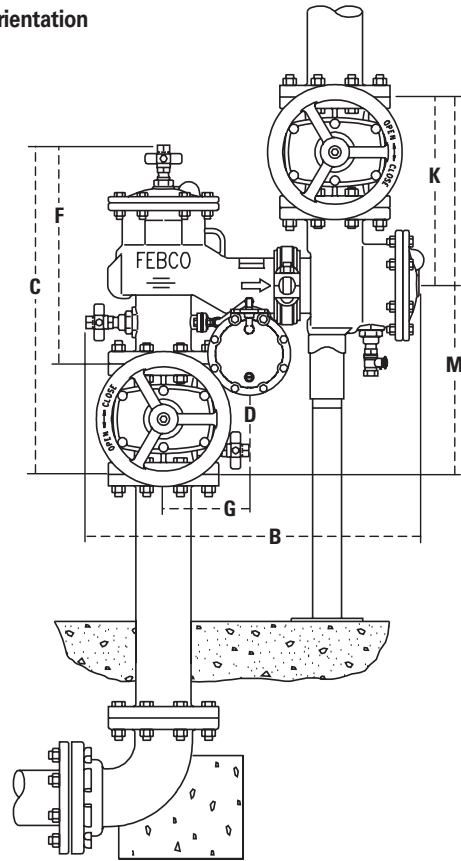

Note: The Model 880V is shipped in the standard (N-Shape) orientation as shown above.

NRS Side View

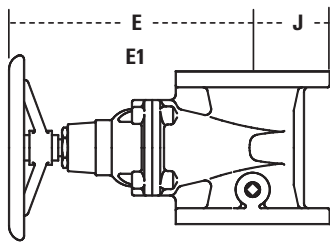

Relief Valve Detail

Relief shipped on right side (shown) field reversible to left side.

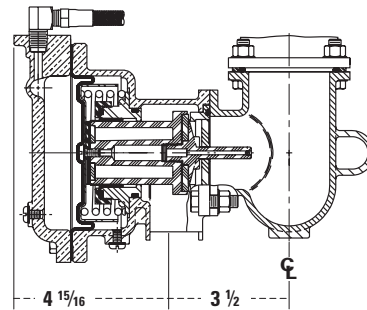

Dimensions – Weights

Size: 2½" - 10" (65 - 80mm)

SIZE (DN)		DIMENSIONS																WEIGHT													
	A	B	C	D	E NRS	E1 OS&Y*	F	G	H	J	K	L	M	NRS	OS&Y																
in.	mm	in.	mm	in.	mm	in.	mm	in.	mm	in.	mm	in.	mm	in.	mm	lbs.	kgs.	lbs.	kgs.												
2½	65	12½	318	25¾	654	24¼	616	4 ¹⁵ / ₁₆	125	12½	321	16%	416	16%	422	6¼	159	5½	140	3½	89	13%	346	7¼	184	27¼	692	210	95	220	100
3	80	12½	318	25¾	654	24¾	629	5 ⁷ / ₁₆	138	12½	327	22¼	565	16%	422	6¼	159	5½	140	3¾	95	14%	359	7¼	184	28¾	718	280	127	290	132
4	100	14	356	27⅞	708	26¾	680	6 ⁹ / ₁₆	167	14¾	365	23¼	591	17¾	451	7	178	6	152	4½	114	15½	394	7¼	184	31	787	320	145	350	159
6	150	16	406	32¼	819	32¼	819	8 ⁹ / ₁₆	218	18%	497	30⅞	765	21 ⁹ / ₁₆	548	8	203	7½	191	5½	140	18%	473	9½	241	37¼	946	480	218	530	240
8	200	18½	470	37½	953	36¾	924	9 ⁹ / ₁₆	243	23½	597	37¾	959	24%	632	9¼	235	8¾	222	6¾	172	20¾	527	10¼	260	41½	1054	810	367	880	399
10	250	21	533	42½	1080	40¾	1035	11½	292	27½	699	48	1219	27½	699	10	254	9¾	248	8	203	24	610	11½	292	48	1219	1350	612	1480	671

*OS&Y OPEN

Weights do not include risers or optional valve setter.

Note: Dimensions shown are nominal. Allowances must be made for normal manufacturing tolerances.

Refer to Specification Sheet ES-F-611 for details on valve setter.

Typical Installation

Standard orientation (Model 880V)

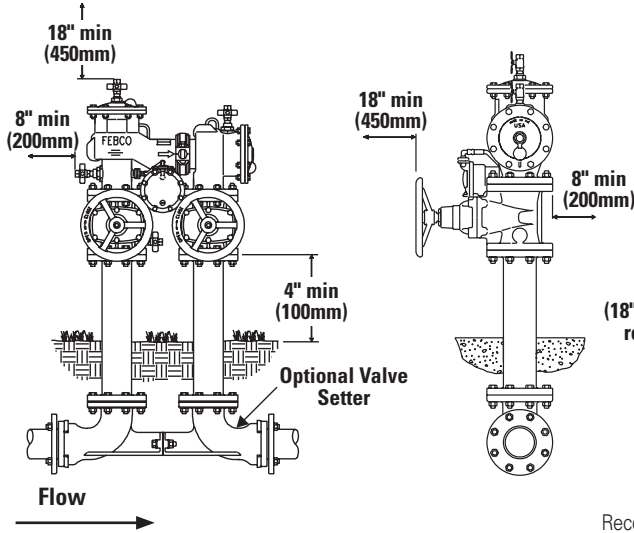

Vertical orientation (Model 880V)

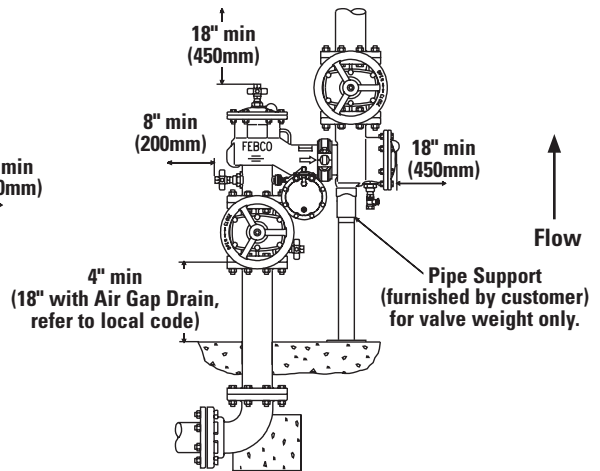

Recommended minimum clearances from permanent structures for ease of testing and maintenance are shown on above drawings.

Capacity

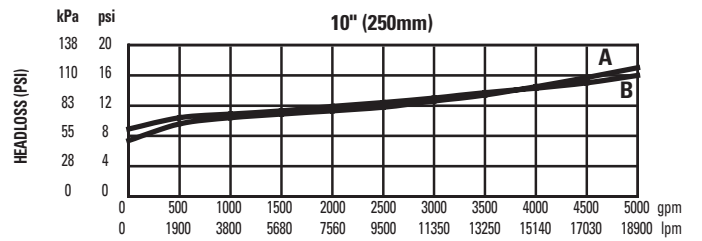
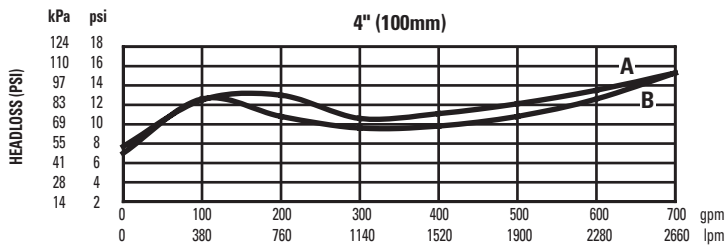
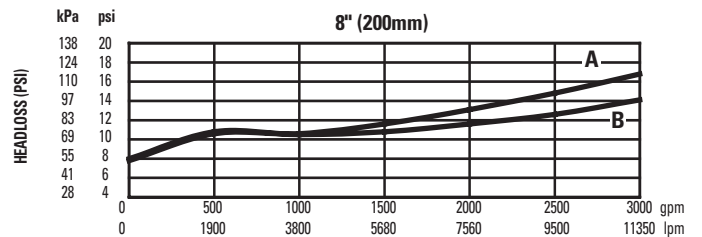
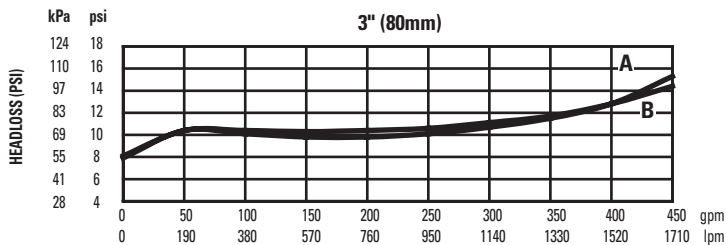
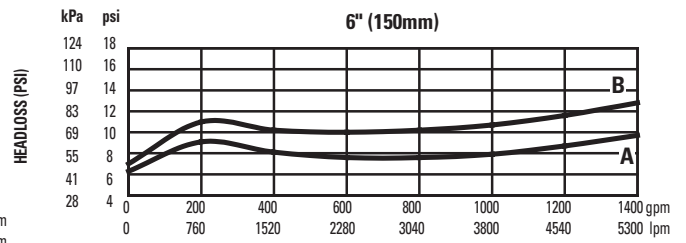
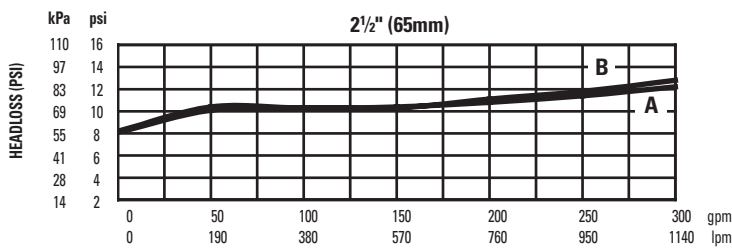

A-Vertical orientation
B-Standard orientation

The 6" and 10" flow curves (B-standard orientation) include the FEBCO valve setter model 611.



A Watts Water Technologies Company



USA: Fresno, CA • Tel: (559) 441-5300 • Fax: (559) 441-5301 • www.FEBCOonline.com
Canada: Burlington, ON • Tel: (905) 332-4090 • Fax: (905) 332-7068 • www.FEBCOonline.ca