

POWERS

A WATTS INDUSTRIES CO.

TECHNICAL INSTRUCTIONS HI/LO SUPPLY FIXTURE SYSTEM Operation, Testing, Maintenance

DESCRIPTION

The Powers 430 Hi/Lo Supply Fixture is a pre-piped system consisting of two thermostatic valves and a PRV, designed to provide consistent temperature control over a wide range of flow requirements.

The unit includes: A Powers Series 430 thermostatic mixing valve, a Powers Series 420 or 427 thermostatic mixing valve, a Pressure Reducing Valve (PRV), pressure gauges, union inlet strainer checkstops, dial thermometer, shut-off ball valve, and interconnecting piping.

All components are pre-assembled for easy installation. The stainless steel or durable white baked enamel steel cabinets are designed for recessed or wall mount installation and provide protected access to the system.

OPERATION

This two valve supply fixture has a low capacity valve that works in parallel with a high capacity valve. During low demand, the low capacity valve will handle the load requirements. As the load demand is increased, the pressure reducing valve, which is set at a certain pressure differential, will open and allow flow through the high capacity valve to assist the low capacity valve in meeting the load requirements.

APPLICATION

This is a typical application of the Hi/Lo Supply Fixture for recirculation. Basic guidelines for recirculating are provided below. Following these guidelines will ensure stable control of the domestic water system during normal and low/no use periods. Improper piping causes the recirculating system to have erratic pressure and temperature fluctuations.

For Capacity requirements, Refer to Form #MV430-3.5 or the **Hi/Lo Supply Fixture Brochure**.

- DO NOT recirculate low temperature hot water (LTHW) and high temperature hot water (HTHW) with one pump; return water may come back hotter than mixer set point.

- To minimize natural heat convection, locate master mixer below hot water source, or install mixer with heat trap (a two-foot drop in the pipe line) as shown.
- Do use two (2) circulating pumps. Use check valves to prevent reverse flow.
- Always use an Aquastat set at a temperature below set point of mixer.
- Be certain HTHW cannot be introduced into cold side of mixer.
- Always** tie LTHW return to cold water side of mixing valve, as well as back to hot water source.

WARNING

DO NOT OMIT THE LTHW CONNECTIONS; scalding and severe personal injury may result from return supply temperatures approaching hot water heater temperatures.

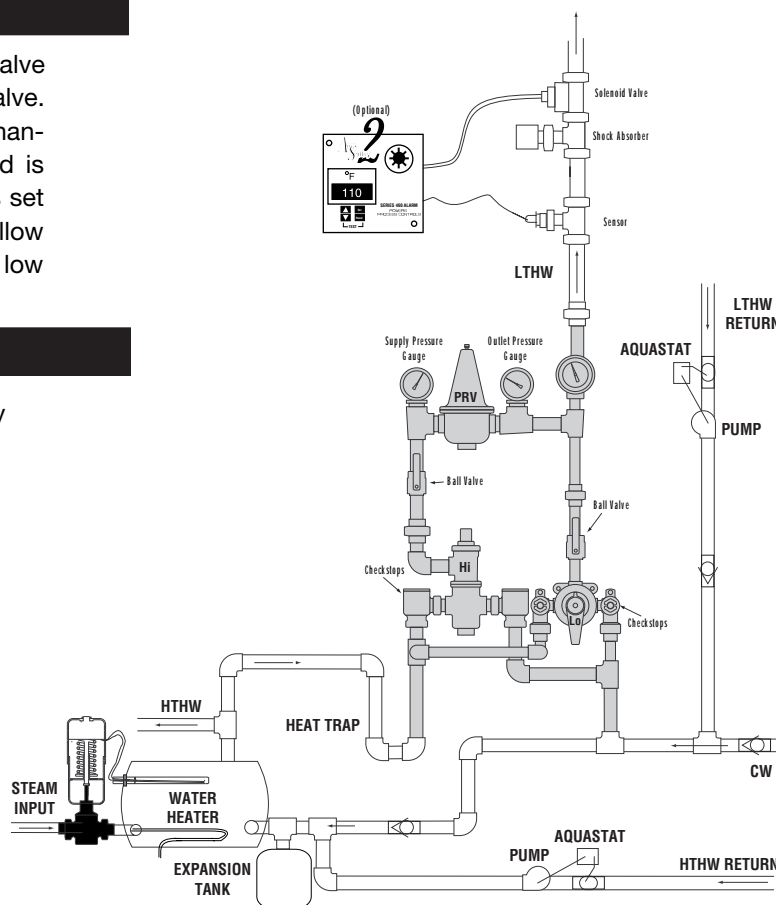

PRIOR TO INSTALLATION

1. Flush all piping thoroughly.
2. Make sure all valve handles are rotated fully clockwise (off).
3. If you use copper tubing, excessive heat from soldering will damage the internal parts of the valve. Take care to protect valve components or remove the internal parts of the valve and checkstops before soldering.
4. **IMPORTANT**
In order to make any temperature adjustments to the valves, **you must open enough showerheads (or end-of-line fixtures) to ensure you have adequate flow across the valve.** For example, the 431 requires a minimum flow of 7 GPM to operate properly. The 420 requires a minimum flow of 2 GPM. Refer to the flow chart for additional information.
5. Use a thermometer at the showerhead or install an in-line thermometer at the point of use..

SET UP PROCEDURE

You MUST FOLLOW THESE PROCEDURES in order to properly adjust your Hi/Lo System.

You need proper flow across the valves in order to set a maximum temperature.

Refer to the Individual Setting Procedures as guided in these directions.

1. Close the 420 Valve by turning the handle fully clockwise.
2. Open the ball valve at the discharge of the 430 series valve.
3. Open one fixture.
4. **Set the PRV** for a 15 psi differential. (See **Setting the PRV**)
5. Close the Ball valve at the discharge of the larger valve and open the smaller valve by rotating the handle fully counterclockwise.
6. Open enough fixtures for a flow of at least:
 - 2 GPM if the small valve is a 420
 - 4 GPM if the small valve is a 427
 - 7.5 GPM if the small valve is a 431
7. **Set the maximum temperature for the smaller valve** (Refer to **Individual Setting Procedures** for the 420, 427 or 430).
8. When the valve has the correct maximum temperature setting, close the smaller valve.
9. Open the ball valve at the discharge of the larger valve.
10. Open additional fixtures so that enough water flows through the larger valve:
 - 7.5 GPM if the large valve is a 431
 - 15 GPM if the large valve is a 432
 - 24 GPM if the large valve is a 433
 - 40 GPM if the large valve is a 434
11. **Set the maximum temperature for the larger valve** (Refer to **Individual Setting Procedures** for the 430).
12. When water is at desired outlet temperature, shut off all end of line fixtures (showerheads).

13. Open the smaller valve.
14. **Test the Control:** Verify temperature control over a wide range of flow by opening a fixture and monitoring the discharge temperature. Gradually open additional fixtures to verify that flow through both valves is properly controlled.
15. For any problems, refer to Troubleshooting.

INDIVIDUAL SETTING PROCEDURES

Set the PRV Valve

The Hi/Lo Assembly has one pressure gauge on each side of the Pressure Reducing Valve. The left measures the supply pressure, the right measures the output pressure going to the fixtures. The PRV should be set so that the outlet pressure gauge is approximately 15 psi less than the supply pressure gauge (a 15 psi differential across the PRV).

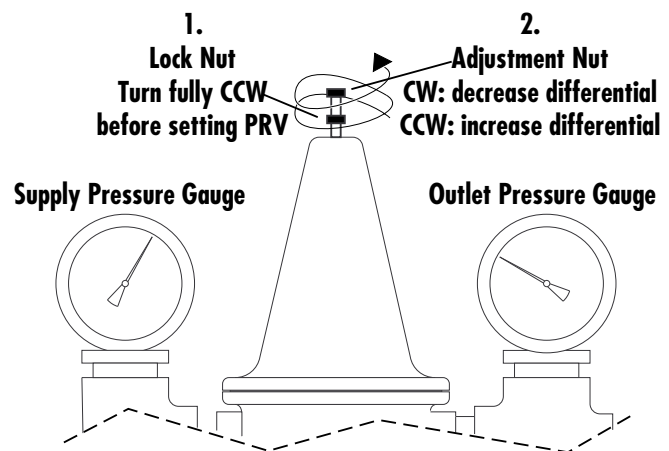

1. Loosen the lock nut at the top of the PRV Valve. This must be all the way out or you will be limiting the range of your adjustments.
2. Adjust the PRV valve so the outlet pressure gauge (right) reads approximately 15 psi less than the supply pressure gauge (left).
Turning the adjustment nut **clockwise** will **decrease the differential** across the PRV (allowing the PRV to open sooner).
Turning the adjustment nut **counterclockwise** will **increase the differential** across the PRV (allowing the PRV to open later).

Adjust the temperature of the 420 valve

The Standard 420 Hydroguard valve was factory set to deliver 115°F [46°C] tempered water.

1. Turn the handle fully counterclockwise to deliver water at the maximum temperature.
2. Loosen and remove handle retaining screw and handle.
3. If the measured temperature exceeds the desired maximum outlet temperature, move the limit stop **one spline**

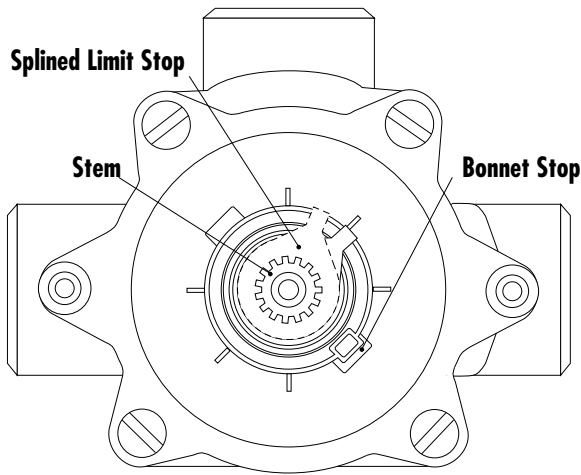

counterclockwise. This will decrease the handle rotation and the maximum adjustable temperature.

If the measured temperature is below the desired maximum outlet temperature, move the limit stop **one spline clockwise**. This will **increase** the handle rotation and the maximum adjustable temperature.

4. When the valve has the correct maximum temperature setting, close the fixtures.
5. Use the handle to close the valve (rotate fully clockwise). Replace valve handle and sleeve and secure with screw.

Adjust the temperature of the 427 valve

The Standard 427/8 Hydroguard valve is factory set to deliver 115°F [46°C] tempered water with hot water supply at 140°F [60°C] and cold water supply at 60°F [16°C].

1. Turn the handle fully counterclockwise to deliver water at the maximum temperature.
2. Remove the handle retaining screw, and the lock washer. Inside the handle will remain 2 lock screws.
3. If the measured temperature exceeds the desired maximum outlet temperature, use an Allen wrench to turn these temperature adjustment screws **clockwise**. This will **decrease** the maximum adjustable temperature.

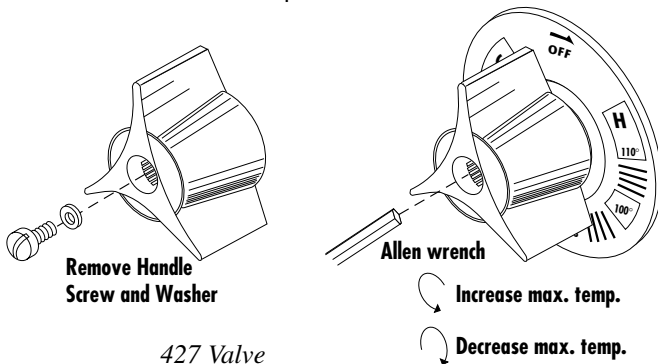

use an Allen wrench to turn these temperature adjustment screws **clockwise**. This will **decrease** the maximum adjustable temperature.

If the measured temperature is below the desired maximum outlet temperature, use an Allen wrench to turn these temperature adjustment screw **counterclockwise**. This will **increase** the maximum adjustable temperature.

4. When the valve has the correct maximum temperature setting, close the fixtures.

5. Use the handle to close the valve (rotate fully clockwise). Replace lock washer and handle retaining screw.

Adjust the temperature of the 430 valve

1. Loosen the temperature adjustment lock screw (on side) with hex key. Turn the knob fully counterclockwise.
2. Hold the knob in place, and use hex key to turn the maximum temperature setting screw (on top). Turn in small increments to let the thermostatic motor adjust. Turn hex key **counterclockwise** to **increase** the maximum temperature

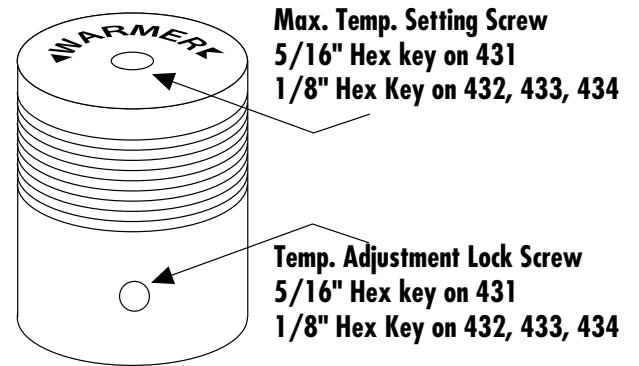

Turn hex key **clockwise** to **decrease** the maximum temperature setting.

3. When water is at desired outlet temperature, tighten temperature adjustment lock screw (hex hole on side) by turning clockwise.

TROUBLESHOOTING

Outlet temperature is too hot with a low flow...

- The maximum temperature of the small valve (420) was not properly set. Refer to **Set Up Procedure** and reset the max. temp. of this valve.
- The thermal motor of the small valve is not working properly. Test and replace according to the appropriate technical instructions (#TI420-1, #TI427, #TI430-1).

Outlet temperature is too hot with a high flow...

- The maximum temperature of the large valve (430) was not properly set. Refer to **Set Up Procedure** and reset the max. temp. of this valve.
- The thermal motor of the large valve (430) is not working properly. Test and Replace according to TI430-1.

Outlet temperature stable, but creeps high overnight...

- The recirculation lines are not properly plumbed. Refer to Application and drawing on page 1.
- The PRV is opening too soon. Refer to **Set Up Procedure** and reset the differential across the PRV.
- The return pump runs constantly. Install and Aquastat on the return pump. Refer to **Application** and drawing on p.1.

Outlet temperature too low on low and high flow...

- The hot water supply temperature is too low. You must have a supply temperature of at least 25°F higher than the set temperature. Readjust hot water supply.
- The checkstops on the hot water side of the valve are not open fully, or may be stuck due to liming. Open, or clean the checkstops (refer to **Maintenance**).
- The temperature has not been set properly on the small and/or large valve. Refer to Set Up Procedure and reset the valves.

Outlet flow drops off...

- The differential across the PRV is set too high, so the larger (430) valve begins controlling the system too late, and “starves” the system. Refer to Set Up Procedure and decrease the differential across the PRV.
- The checkstop on the 430 valve are not fully open or are stuck due to liming. Open, or clean the checkstops (refer to Maintenance).
- The system pressure varies by more than 50% of inlet supply pressure.

Outlet temperature cycles between hot and cold...

- The differential across the PRV is set too low, so the larger (430) valve begins controlling the system too early, and therefore cycles (hunts for the set point). Refer to Set Up Procedure and increase the differential across the PRV.
- The system pressure varies by more than 50% of inlet supply pressure.

CALIFORNIA PROPOSITION 65 WARNING

WARNING: This product contains chemicals known to the State of California to cause cancer and birth defects or other reproductive harm. (Installer: California law requires that this warning be given to the consumer.)

For more information: www.wattsind.com/prop65

PREVENTIVE MAINTENANCE

Thermostatic water mixing valves are control devices which must be cleaned and maintained on a regular basis.

- For additional information on the 430 series valves, please refer to **Form #TI430-1**. For additional information on the 420 series valves, please refer to **Form #TI420-1**. For additional information on the 427 series valves, refer to **Form #TI427**.
- Before servicing checkstops or piping, turn off the supply water upstream. At least every twelve months, open up the checkstops and check for free movement of the poppet.
For the 430 checkstops, use a 1/4" hex key. Turn counterclockwise to open and clockwise to close.
For 420 checkstops, use a slotted screwdriver. Turn counterclockwise to open and clockwise to close.
- Before servicing the valves, turn off the water supply upstream OR access and close the checkstops. To close the checkstops, turn the adjustment screw on each fully clockwise.
- When opening checkstops after servicing, do not over adjust; make sure the center of the stop is still pushed in.
- Every three months, check the maximum temperature adjustments.

CAUTION: Any change in supply condition will affect the outlet water temperature. Check and adjust the valves accordingly to prevent injury to users.

- Every twelve months, remove the valve bonnets and check the internal components for freedom of movement. Test the thermostatic motor as described in **Thermostatic Motor Testing** in the appropriate technical instructions. Replace seals if cracked, cut or worn.

Powers Process Controls warrants that the equipment manufactured by it is free from defects in material and workmanship and, without charge, equipment found to be defective in material and workmanship will be repaired, or at Seller's option, replaced f.o.b. original point of shipment, if written notice of failure is received by Seller within one (1) year after date of shipment, provided said equipment has been properly installed, operated in accordance with Seller's instructions, and provided such defects are not due to abuse or chemical decomposition by chemical or galvanic action. This express warranty is in lieu of and excludes all other warranties, guarantees, or representations, express or implied. There are no implied warranties or merchantability or of fitness for a particular purpose. The Seller assumes no responsibility for repairs made on the Seller's equipment unless done by Seller's authorized personnel, or by written authority from the Seller. The Seller makes no guarantee with respect to material not manufactured by it.



USA office: Phone: 800.669.5430 • Fax: 847.824.0627
www.powerscontrols.com
 Canadian office: Phone: 888.208.8927 • Fax: 888.882.1979
 © 2002 Powers, a Watts Industries Co.