

Series 757a, 757aDCDA 757Na, 757NaDCDA

Double Check Valve Assemblies
Double Check Detector Assemblies

Sizes: 2½" – 6" (65 – 150mm)

- Installation
- Service
- Repair Kits
- Maintenance

For field testing procedure, send for IS-TK-DL, IS-TK-9A, IS-TK-99E and IS-TK-99D.

For other repair kits and service parts, send for PL-RP-BPD and F-RK-DC.

For technical assistance, contact your local Watts representative.

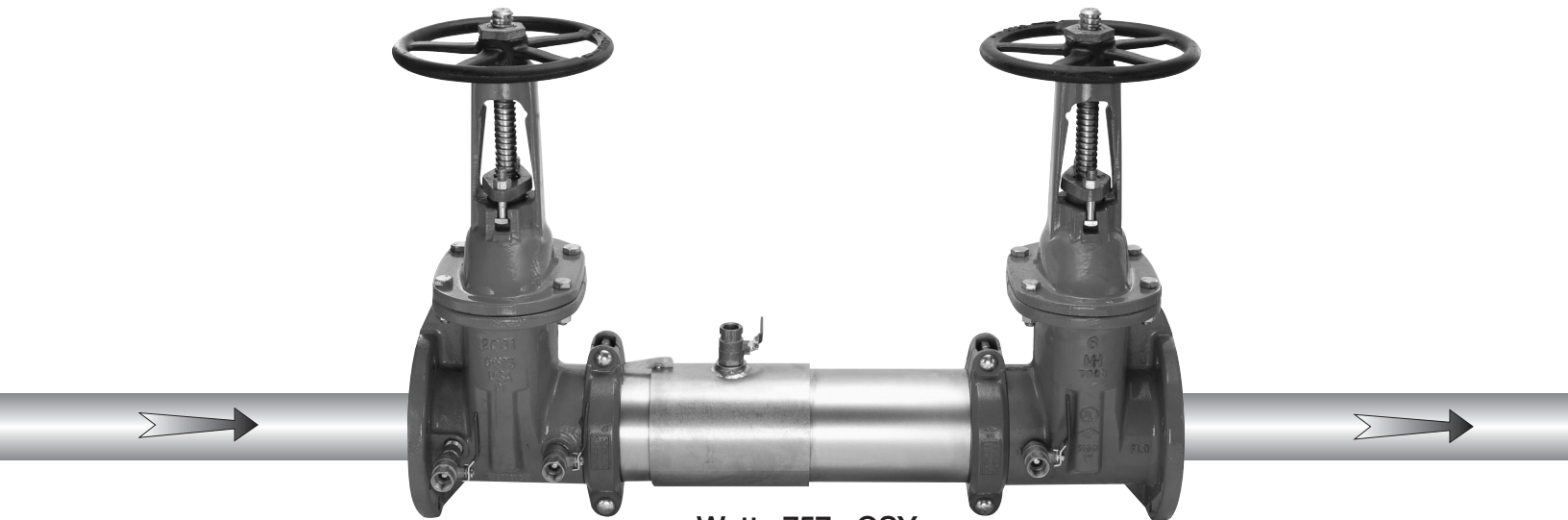

Watts 757a OSY

CALIFORNIA PROPOSITION 65 WARNING

WARNING: This product contains chemicals known to the State of California to cause cancer and birth defects or other reproductive harm. (California law requires this warning to be given to customers in the State of California.)

For more information: www.watts.com/prop65

IMPORTANT: Inquire with governing authorities for local installation requirements.

NOTE: For Australia and New Zealand: Pipeline strainers should be installed between the upstream shutoff valve and the inlet of the backflow preventer.

It's important that this assembly be tested periodically in compliance with local codes, but at least once per year or more as service conditions warrant. If installed on a fire sprinkler system, all mechanical checks, such as alarm checks and backflow preventers, should be flow tested and inspected internally in accordance with NFPA 13 and NFPA 25.

Limited Warranty: Watts Regulator Co. (the "Company") warrants each product to be free from defects in material and workmanship under normal usage for a period of one year from the date of original shipment. In the event of such defects within the warranty period, the Company will, at its option, replace or recondition the product without charge.

THE WARRANTY SET FORTH HEREIN IS GIVEN EXPRESSLY AND IS THE ONLY WARRANTY GIVEN BY THE COMPANY WITH RESPECT TO THE PRODUCT. THE COMPANY MAKES NO OTHER WARRANTIES, EXPRESS OR IMPLIED. THE COMPANY HEREBY SPECIFICALLY DISCLAIMS ALL OTHER WARRANTIES, EXPRESS OR IMPLIED, INCLUDING BUT NOT LIMITED TO THE IMPLIED WARRANTIES OF MERCHANTABILITY AND FITNESS FOR A PARTICULAR PURPOSE.

The remedy described in the first paragraph of this warranty shall constitute the sole and exclusive remedy for breach of warranty, and the Company shall not be responsible for any incidental, special or consequential damages, including without limitation, lost profits or the cost of repairing or replacing other property which is damaged if this product does not work properly, other costs resulting from labor charges, delays, vandalism, negligence, fouling caused by foreign material, damage from adverse water conditions, chemical, or any other circumstances over which the Company has no control. This warranty shall be invalidated by any abuse, misuse, misapplication, improper installation or improper maintenance or alteration of the product.

Some States do not allow limitations on how long an implied warranty lasts, and some States do not allow the exclusion or limitation of incidental or consequential damages. Therefore the above limitations may not apply to you. This Limited Warranty gives you specific legal rights, and you may have other rights that vary from State to State. You should consult applicable state laws to determine your rights. **SO FAR AS IS CONSISTENT WITH APPLICABLE STATE LAW, ANY IMPLIED WARRANTIES THAT MAY NOT BE DISCLAIMED, INCLUDING THE IMPLIED WARRANTIES OF MERCHANTABILITY AND FITNESS FOR A PARTICULAR PURPOSE, ARE LIMITED IN DURATION TO ONE YEAR FROM THE DATE OF ORIGINAL SHIPMENT.**

WATTS®

Basic Installation Instructions

Guidelines

Most field problems occur because dirt and debris present in the system at the time of installation becomes trapped in the #1 check. The system should be flushed before the backflow valve is installed. If the system is not flushed until after the backflow valve is installed, remove both check modules from the valve and open the inlet shutoff to allow water to flow for a sufficient time to flush debris from the water line. If debris in the water system continues to cause fouling, a strainer can be installed upstream of the backflow assembly.

Watts models 757a and 757aDCDA may be installed in either horizontal or vertical position as long as the backflow assembly is installed in accordance with the direction of the flow arrow on the assembly and the local water authority approves the installation. The assembly should be installed with adequate clearance around the valve to allow for inspection, testing and servicing. 12" should be the minimum clearance between the lower portion of the assembly and the floor or grade.

Note: Assembly body should not be painted.

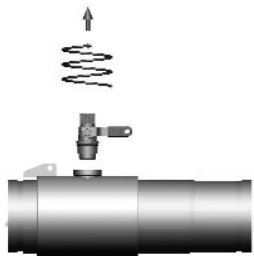
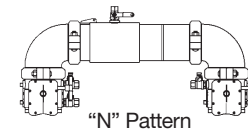
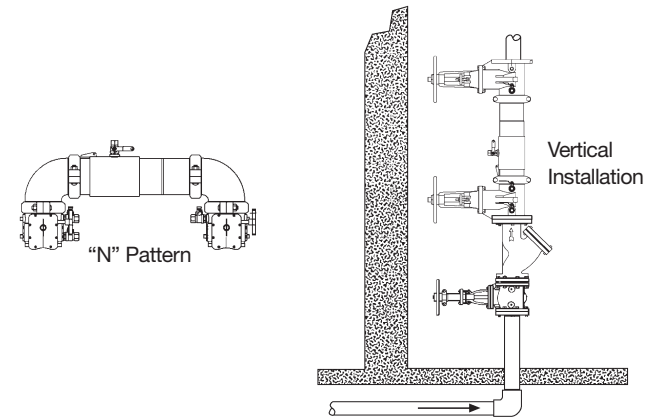
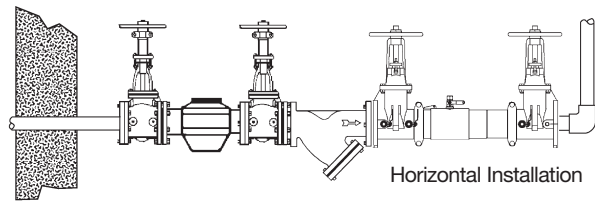

Figure A

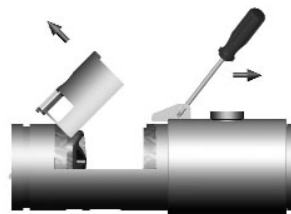

Figure B



Figure C

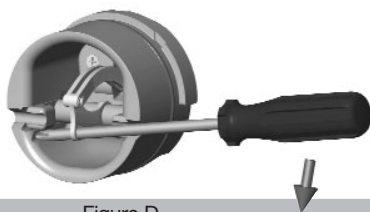

Figure D



Figure E



Figure F

Prior to servicing any Watts valve, it is mandatory to shut down the water system by closing both the inlet and outlet shutoff valves. After shutoff valves are closed, open test cock #2, #3 and #4 to relieve pressure within the backflow assembly.

1. After #3 test cock has been opened to relieve pressure, remove #3 test cock from housing. (Figure A)
2. Insert a #3 screwdriver through the hole on the top of the cover sleeve and using both hands rotate the cover sleeve approximately 1/4-turn clockwise and 1/4-turn counter-clockwise to break the sleeve O-ring seals. Using the screwdriver, slowly slide the cover sleeve to the downstream side of the housing. (Figure B)
3. Remove the stainless steel check retainer from the housing. (Figure B)
4. Remove the #1 check module (Figure C) by inserting two flat blade screwdrivers into the slots on either side of the check module and gently pry the check module toward the open zone.

5. Remove #2 check module with the same instructions as in #4 above.
6. To clean or inspect either check module, insert a #3 screwdriver through the downstream side of the check module as shown in Figure D and E. When the screwdriver is in place, remove the E-clip (Figure F) and pin connecting the structural members and the check clapper will open with no tension.
7. Thoroughly clean the seating area. The sealing disk may be removed, if necessary, by removing the screws connecting the keeper plate to the clapper. The sealing disc may be reversed and reinstalled if the elastomer is cut or damaged.
8. Wash check module and O-ring and inspect for any damage. If damaged, reinstall new parts.
9. After thorough cleaning, lubricate O-ring w/FDA approved lubricant, replace pin and E-clip in structural members, remove screw driver and reinstall check modules and assemble housing in reverse order of these instructions.

Test Procedures

Double Check Valve Assemblies

Test Check Valve No.1

- Step 1: Ensure shutoff #1 is open, shutoff #2 is closed.
- Step 2: Connect high side hose to test cock #3, low side to test cock #2 and open both test cock #2 and test cock #3.
- Step 3: Open valve C, then open A to bleed air from the high side. close valve a, then open B to bleed low side. Close valve B.
- Step 4: Connect vent hose loosely to test cock#1. Open valve A to vent air from vent hose, Tighten vent hose at test cock #1, open test cock #1.
- Step 5: Close shutoff #1. Slowly loosen hose at test cock #2 until differential gauge rises to 2psi and retighten hose. If the differential reading does not decrease, record check valves as "tight".

Test Check Valve No. 2

- Step 1: Move the high side hose to test cock #4, low side to test cock #3 and open both test cock #3 and test cock #4. Remove vent hose from test cock #1, open shutoff #1.
- Step 2: Open valve C, then open valve A to bleed air from the high side. Close valve A, then open valve B to bleed low side. Close valve B.
- Step 3: Connect vent hose loosely to test cock #1. Open valve A to vent air from the vent hose. Tighten vent hose at test cock #1, open test cock #1.
- Step 4: Close shutoff #1, then slowly loosen hose at test cock #3 until differential gauge rises to 2psi and retighten hose. If the differential reading does not decrease, record check as tight. Remove all hoses and restore valve to original working condition.

Note: The assembly will fail both the first and second check valve tests above, if shutoff #2 leaks excessively. To test for a leaky #2 shutoff, use the following procedure.

Test for Leaky No. 2 shutoff

- Step 1: Connect the high side to test cock #1, low side to test cock #4. Open test cock #1 and test cock #4. Close shutoffs #1 and #2.
- Step 2: Close valve C. Open valve A, then open valve B 1/2 turn, loosen hose at test cock #4 to remove air. Retighten hose.
- Step 3: If the differential gauge rises above 0, there is excessive leakage at shutoff #2 and it must be replaced to test the assembly.

Ball Type Test Valves

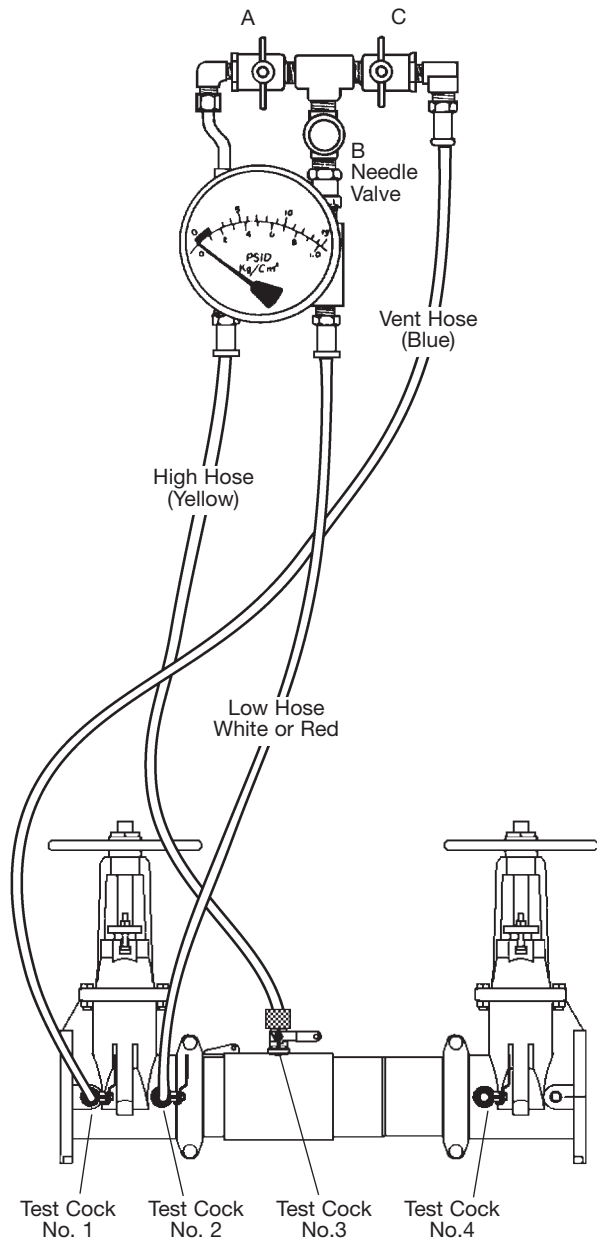

757a, 757aDCDA Repair Kits

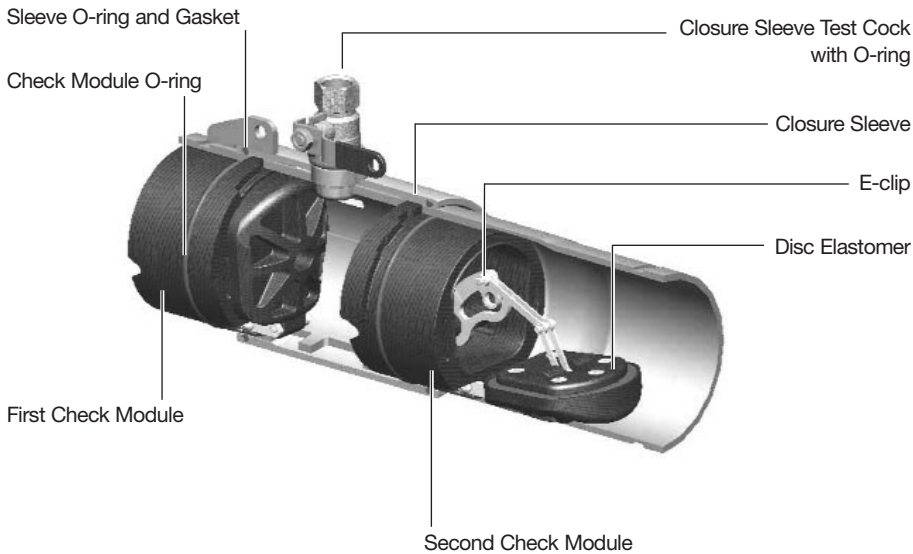

| ORDERING NO. | SIZE | DISC | MODEL |
|--------------|------|------|-------|
|--------------|------|------|-------|

1st Check Kits

| | | | |
|---------|----------|------|----------------------|
| 0899250 | 2½" - 4" | EPDM | RK 757a/757aDCDA CK1 |
| 0899251 | 6" | EPDM | RK 757a/757aDCDA CK1 |

Kit consists of: First check module, Check module O-ring, Disc elastomer

2nd Check Kits

| | | | |
|---------|----------|------|----------------------|
| 0899254 | 2½" - 4" | EPDM | RK 757a/757aDCDA CK2 |
| 0899255 | 6" | EPDM | RK 757a/757aDCDA CK2 |

Kit consists of: Second check module, Check module O-ring, Disc elastomer

| ORDERING NO. | SIZE | DISC | MODEL |
|--------------|------|------|-------|
|--------------|------|------|-------|

1st or 2nd Check Rubber Parts Kits

| | | | |
|---------|----------|------|----------------------|
| 0899258 | 2½" - 4" | EPDM | RK 757a/757aDCDA RC4 |
| 0899259 | 6" | EPDM | RK 757a/757aDCDA RC4 |

Kit consists of: Check module O-ring, Disc elastomer and E-clip

1st or 2nd Check Cover Kits

| | | | |
|---------|----------|---|--------------------|
| 0899266 | 2½" - 4" | – | RK 757a/757aDCDA C |
| 0899267 | 6" | – | RK 757a/757aDCDA C |

Kit consists of: Closure sleeve, 2 pieces of sleeve O-ring



A Watts Water Technologies Company



USA: 815 Chestnut St., No. Andover, MA 01845-6098; www.watts.com

Canada: 5435 North Service Rd., Burlington, ONT. L7L 5H7; www.wattscanada.ca