

Watts Model L111

Thermostatic Mixing Valve

Installation Instructions

Valve should be installed by a licensed contractor in accordance with local codes and ordinances.

A. Mounting the Valve*

1. Remove cover screw using the Allen wrench supplied.
2. Remove the tamper-proof cover.
3. Secure the L111 valve body to the wall using four #10 screws.

* Valve should be installed in a location where it is accessible for cleaning, service, or adjustment.

NOTE: Allow sufficient clearance to remove tamper-proof cover.

B. Piping**

1. Close both the hot and cold water supply shutoff valves upstream of the intended installation.
2. Bleed the remaining water from the system.
3. Connect the water supply to the L111 valve as shown in Fig. 1. Supply piping must be flushed clean before making connections to the valve.
4. Install Watts Series CS-U combination shutoff/check valve/strainer or separate check valve, strainers and shutoff valves upstream of the L111 or to facilitate servicing and temperature adjustment of the valve.
5. Start Up — Open cold water supply then hot water supply. Inspect for leaks.

** Attach the piping as follows:
 Red label — hot water inlet;
 Blue label — cold water inlet;
 White label — mixed water outlet.

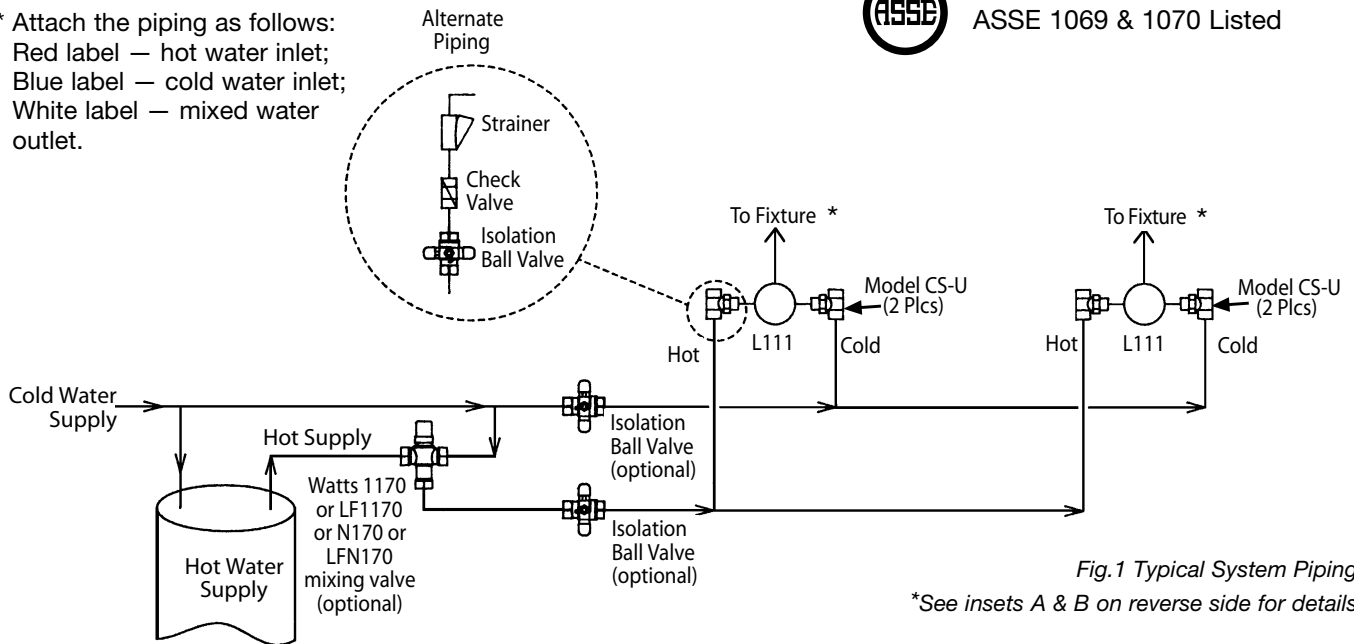

Fig.1 Typical System Piping.

*See insets A & B on reverse side for details.



ASSE 1069 & 1070 Listed

IMPORTANT: This valve must be maintained on a regular basis. Please see reverse side for instructions.

CAUTION: Do not use this valve on systems using a recirculation device. Systems that use recirculation to maintain selected water temperature in supply piping must incorporate master mixing valves such as the Watts Series 1170, LF1170, N170, or LFN170.

WARNING

Water Temperatures in Excess of 110°F (43°C) Are Dangerous and May Cause Scalding, Severe Injury or Death!
 This valve is not factory pre-set. To deliver the desired mixed water temperature at the outlet the installer must adjust and verify the temperature at the outlet.

IMPORTANT

This valve can be adjusted to deliver water at temperatures exceeding 110°F (43°C). Consequently, after installing the Watts L111 Thermostatic Mixing Valve, you should always check the outlet water temperature and adjust the valve to ensure delivery of water at a safe temperature not exceeding 110°F (43°C). Further, check valves and strainers must be installed in the hot and cold water supply lines to this valve. Mechanical valves are not failsafe. Due to the effects of various water conditions, periodic verification of water temperature is required.

Installation continued

C. Temperature Adjustment

1. Open hot and cold water supply valves.
2. Open mixed water outlet.
3. With the fixture in the full open position, calibrate the mixed water outlet temperature by placing a thermometer in the mixed water stream. Adjust the setting of the L111 valve to obtain the desired temperature (counter-clockwise, to increase temperature – clockwise to decrease temperature).

D. Secure Setting

1. Reinstall the tamper-proof cover and secure it with the cover screw and Allen wrench supplied.

E. Periodic Inspection/Maintenance

This valve requires periodic inspection and verification of the outlet temperature by a licensed contractor. Corrosive water conditions, hot feed water temperatures over 200°F (93°C), unauthorized adjustments or repair could render the valve ineffective for its intended service. Regular cleaning and checking of thermostat assembly helps to maximize valve life and mixing function. Frequency of cleaning depends on local water conditions.

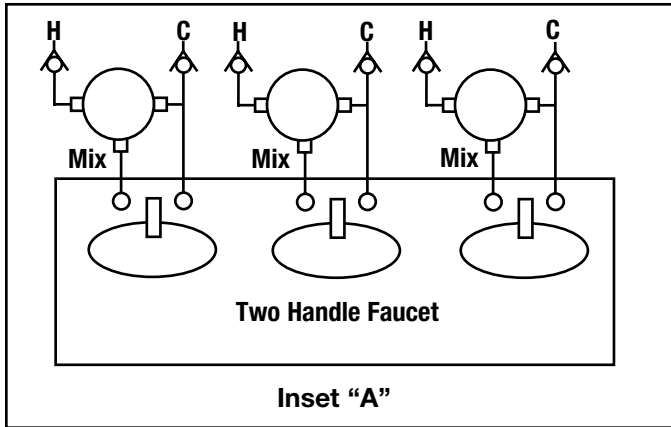

ASSE 1070 Application

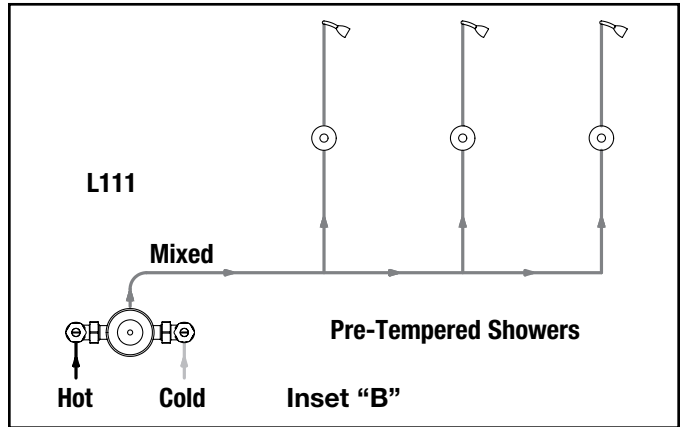

ASSE 1069 Application

Watts product specifications in U.S. customary units and metric are approximate and are provided for reference only. For precise measurements, please contact Watts Technical Service. Watts reserves the right to change or modify product design, construction, specifications, or materials without prior notice and without incurring any obligation to make such changes and modifications on Watts products previously or subsequently sold.

CALIFORNIA PROPOSITION 65 WARNING

WARNING: This product contains chemicals known to the State of California to cause cancer and birth defects or other reproductive harm. (California law requires this warning to be given to customers in the State of California.)

For more information: www.watts.com/prop65

Limited Warranty: Watts Regulator Co. (the "Company") warrants each product to be free from defects in material and workmanship under normal usage for a period of one year from the date of original shipment. In the event of such defects within the warranty period, the Company will, at its option, replace or recondition the product without charge.

THE WARRANTY SET FORTH HEREIN IS GIVEN EXPRESSLY AND IS THE ONLY WARRANTY GIVEN BY THE COMPANY WITH RESPECT TO THE PRODUCT. THE COMPANY MAKES NO OTHER WARRANTIES, EXPRESS OR IMPLIED. THE COMPANY HEREBY SPECIFICALLY DISCLAIMS ALL OTHER WARRANTIES, EXPRESS OR IMPLIED, INCLUDING BUT NOT LIMITED TO THE IMPLIED WARRANTIES OF MERCHANTABILITY AND FITNESS FOR A PARTICULAR PURPOSE.

The remedy described in the first paragraph of this warranty shall constitute the sole and exclusive remedy for breach of warranty, and the Company shall not be responsible for any incidental, special or consequential damages, including without limitation, lost profits or the cost of repairing or replacing other property which is damaged if this product does not work properly, other costs resulting from labor charges, delays, vandalism, negligence, fouling caused by foreign material, damage from adverse water conditions, chemical, or any other circumstances over which the Company has no control. This warranty shall be invalidated by any abuse, misuse, misapplication, improper installation or improper maintenance or alteration of the product.

Some States do not allow limitations on how long an implied warranty lasts, and some States do not allow the exclusion or limitation of incidental or consequential damages. Therefore the above limitations may not apply to you. This Limited Warranty gives you specific legal rights, and you may have other rights that vary from State to State. You should consult applicable state laws to determine your rights. **SO FAR AS IS CONSISTENT WITH APPLICABLE STATE LAW, ANY IMPLIED WARRANTIES THAT MAY NOT BE DISCLAIMED, INCLUDING THE IMPLIED WARRANTIES OF MERCHANTABILITY AND FITNESS FOR A PARTICULAR PURPOSE, ARE LIMITED IN DURATION TO ONE YEAR FROM THE DATE OF ORIGINAL SHIPMENT.**



A Watts Water Technologies Company



USA: 815 Chestnut St., No. Andover, MA 01845-6098; www.watts.com

Canada: 5435 North Service Rd., Burlington, ONT. L7L 5H7; www.wattscanada.ca